

C-CHANNEL CATALOGUE



SFSP
Specialized Factory
for Steel Products /s.a.r.l
www.sfsp-lebanon.com

INDEX

- About SFSP	4
- General Information	12
- Channels	17
- Toothed Channels	66
- Fittings	70
- Accessories	76
- Anchors	82

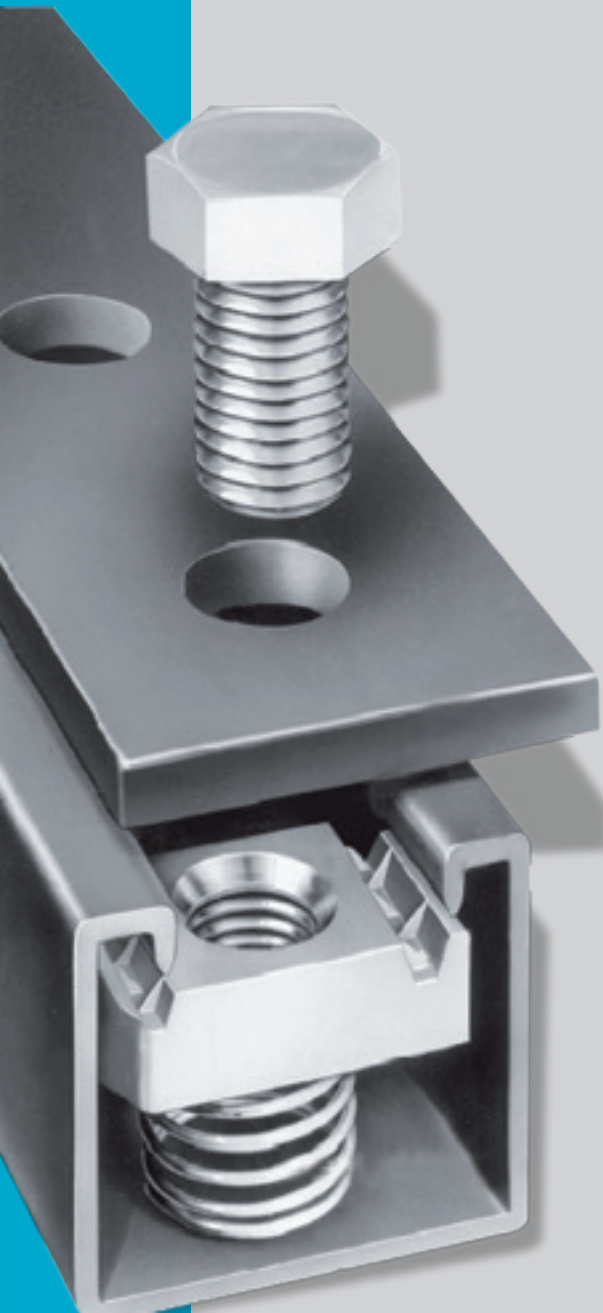

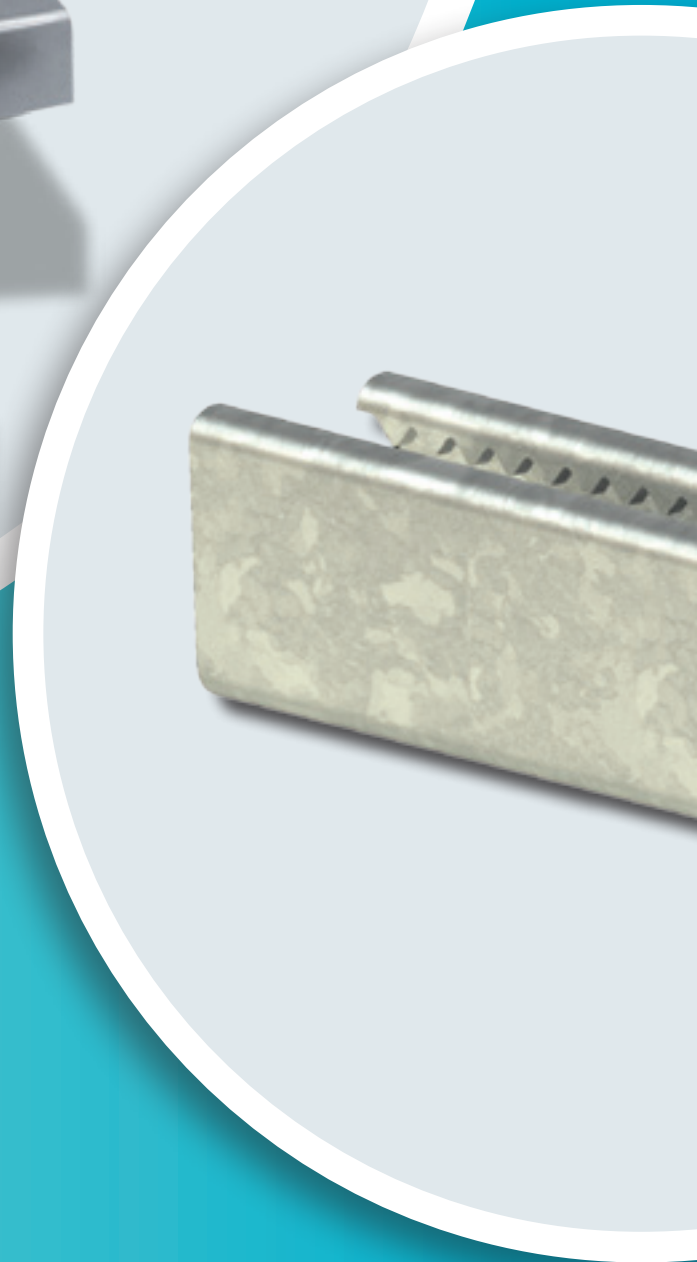





SFSP
Specialized Factory
for Steel Products /s.a.r.l
www.sfsp-lebanon.com

Specialized Factory for Steel Products is a leading factory in Lebanon, established in the year 2011 to serve the steel construction products industry in Lebanon and the region.

Production at the factory is observed using modern practices of manufacturing methods in the steel construction industry with a definite compliance to international standards of fabrication.

SFSP adapts quickly and easily to market demands and requirements. The factory is operating a top of the line production machinery, automated with high technology to ensure quality and maintain speed with delicacy.

Quality at SFSP is uncompromised; the factory is working as per ISO 9001: 2008 Quality Management System, with care for the safety of its workers and clients as well as the welfare of its society by acknowledging the environmental key issues, trying to maintain a pollution-free production facility

TECHNICAL SERVICES

A crucial factor in the job of a factory is to provide continuous technical services and consultations.

That's why SFSP has invested in a professional team of researchers and specialists.

SFSP has recruited brilliant graduates and experienced engineers having the appropriate knowhow on the on latest technology changes and development in the steel building materials industry.

The product range is developed and updated according to the relevant standards of fabrication across markets, whilst the business processes are evaluated to achieve maximum efficiency.

SFSP R&D Core Objectives

- Carry out responsibilities effectively in a safe and healthy work environment.
- Develop and implement research programs relevant to the products and solutions introduced and ensure that the results are communicated clearly in-house and among the clients , concisely and accurately.

SOCIAL RESPONSIBILITY

Being socially responsible is a part of who we are and how we do our business. We aim to provide useful products and services, to provide jobs and development opportunities for our communities, and to gain satisfaction through meaningful work.

We make a difference by acting on the values and principles of our societies and we inspire others to do so. At SFSP, we anticipate and reduce threats caused by environmental changes or natural disasters, and we are well adapted to significant social changes.

We contribute to a more sustainable society by means of value and support to our consumers, supply chains, and stakeholders. We are keen to identify ways they can improve our impacts on the people and places we work and live in, and thereby become more valuable and valued members of society.

- Organizational governance: We promote accountability and transparency at all levels, thus, promoting responsibility
- Human care: We treat individuals with respect; and make efforts to help members of vulnerable groups
- Labor practices: We provide just, safe and favorable conditions to workers
- Environment: At SFSP, we identify and improve environmental impacts of our operations, including the resource use of natural resources and waste disposal.
- Fair operating practices: Practicing accountability and fairness in dealings with other businesses

At SFSP, we are committed to continuous improvement ongoing learning, process review and innovative thinking that foster new initiatives; and better practices. Our environmental programs evolve to meet today's changing needs while; protecting resources for future; generations.



ENVIRONMENTAL AWARENESS

SFSP is committed to the following:

- Compliance with all statutory and regulatory requirements related to its activities, products and services and the environmental aspects.
- Identifying quality and environmental objectives by review and audit of the processes both in-house and on-site.
- Formally setting objectives based on the results of the process reviews and their significance in relation to their impact on the environment and the continual improvement of the quality and environmental management system.
- Implementing management programs to achieve these objectives.
- Investing in a well-trained and motivated workforce.
- Working closely with suppliers and customers to ensure mutual understanding and benefits of the environmental aspects consideration.
- Reviewing our policy and objectives as part of the Management Review Process.
- Communicating this policy to all persons working for or on behalf of the organization.
- Preventing and minimizing Pollution to the environment.



LOCATION

SFSP / Lebanon

management@sfsp-lebanon.com

Specialized Factory for Steel Products / s.a.r.l

Tanayel, Bekaa

Tel: +961 8 514 290

Fax: +961 8 514 291

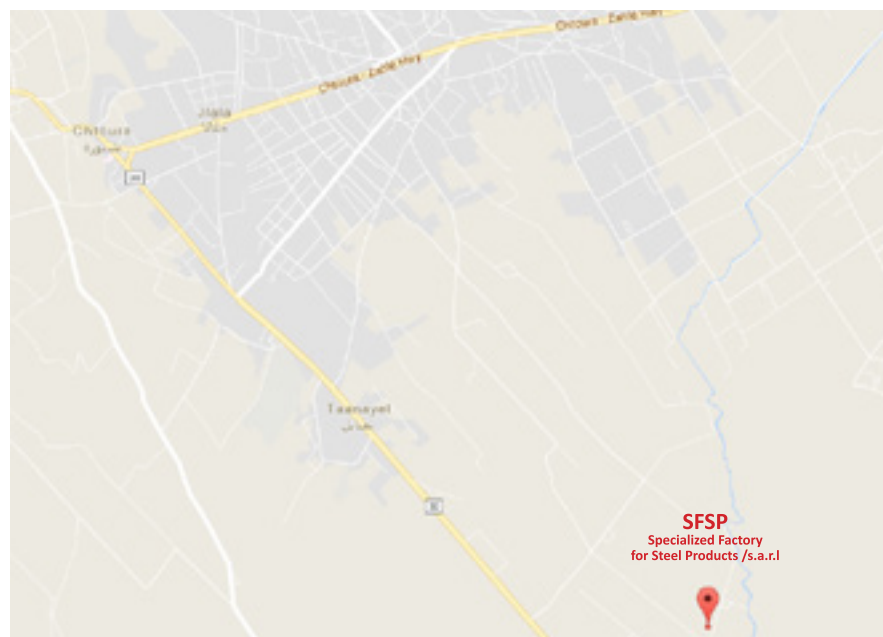

HEALTH AND SAFETY

The Factory Management regard the health and safety of the employees, clients and all others that may be affected by their operations to be of a major importance.

In support of this, the management promotes health and safety throughout the Factory's operations and endeavour to engender a positive attitude in all employees towards the prevention of accidents and maintenance of healthy working arrangements.

The Factory satisfies the requirements of the Health, Safety and related legislation by setting out the responsibilities of all levels of staff and the arrangements for carrying out those responsibilities and in particular do what is reasonably practicable to:

1. Maintains safe & healthy working conditions.
2. Ensures that all facilities and equipment are safe and properly maintained.
3. Provides products that can be applied and used safely and without risk to health.
4. Provides and maintain working procedures, that are safe and without risk to health, throughout the its operations in respect of:
 - The use, handling, storage, transports and disposal of materials and substances.
 - The use of factory equipment.
 - Potential emergency situations, including first aid, fire and escape of substances.
5. Ensure the competence of employees.



SFSP facilities are equipped with advanced machinery amongst are Cable Management Production Lines, Steel cladding systems production lines, metal lathes and blockwork production line, garbage and linen chutes production line, and also partition and ceiling profiles production capacity, and Computerized Numerical Cut machines to ensure delicacy and speed of delivery.

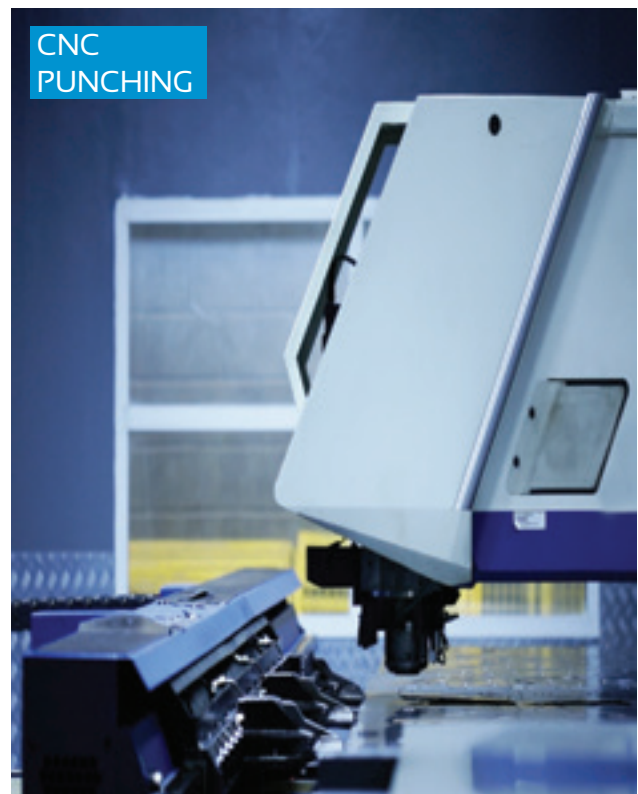

SFSP PRODUCTS

SFSP produces a variety of products ranging from cable management systems; cable trays, cable ladders, basket trays, trunkings and support systems, to mechanical cladding fixations, steel lintels and block work accessories, plasterers' beads, expanded metal and block work reinforcement, strut channel systems, pipe clamps & hangers, gypsum profiles as well as garbage and linen chutes. With the introduction of new machines and the enhancement of production methods, SFSP continues to develop its production methods systematically as well as thoroughly.

CABLE TRAYS & ACCESSORIES

Cable Trays are designed to meet most requirements of cable and electrical wire installations and comply to local and international standards of fabrications and finishes.

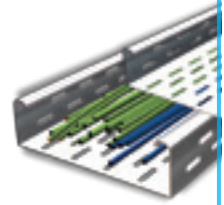

CABLE LADDERS (WELDED & SWAGED)

Cable Ladders of different side heights are available upon request.

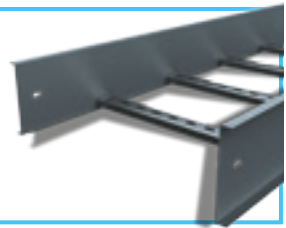

BASKET TRAYS & ACCESSORIES

SFSP's Basket Tray systems make connections fast and simple with limited need for tools. Its design allows for continuous airflow, and prevents heating up of cables. SFSP's Basket Tray comes in a full range of sizes and is made with high-strength welded steel wires.

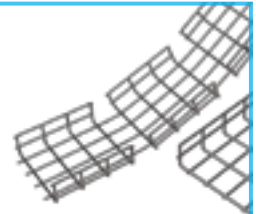

CABLE TRUNKINGS

Cable Trunkings and Accessories are offered in a comprehensive range. Mill galvanized, hot-dip galvanized, and powder coated are the various finishes produced in our factories.



UNDERFLOOR TRUNKING

Underfloor Trunking Systems solutions incorporate a range of products for the distribution of power and data services , it is a coordinated set of containments that protect, segregate, contain, and route cables within a given environment.



CABLE MANAGEMENT SUPPORT SYSTEMS

Cable Support Systems are well designed to provide necessary support for cable trays, cable ladders and trunkings. Cable supports are manufactured according to common standards from high quality raw materials.



C-CHANNEL STRUT SYSTEMS

SFSP's Metal Framing Systems provide an economical solution for electrical, mechanical and industrial supports with a wide variety of applications in the construction industry.

Applications: - Pipe and Conduit Supports - Tunnel Pipe Stanchions - Racks and Shelvings - Wall Framings.



EXPANDED METALS, PLASTERERS' BEADS

Expanded Metals help the formation of joints, protection of corners and resistance against cracks, chips and impact damage.

BLOCK LADDER REINFORCEMENT

SFSP ladder and truss types are used for the reinforcement of brick and block masonry to give improved tensile strength to walls subjected to lateral loading e.g. wind and seismic. SFSP block reinforcements reduces the risk of cracking either at stress concentration around opening.

STEEL LINTELS & BLOCK WORK ACCESSORIES

Steel Lintels provide a combination of strength and light weight, resulting in efficient load bearing performance and increased productivity on site. They are characterized by their ease of installation in addition to time as well as money saving.



PIPE CLAMPS & HANGERS

Pipe Clamps and Hangers from SFSP used in the support of pipes and equipments are manufactured according to the highest standards of fabrication. A diversified choice of Pipe Hangers, Pipe Clamps, EMT Straps, Omega Clamps, Beam Clamps, J and U-Bolts and Threaded Accessories.

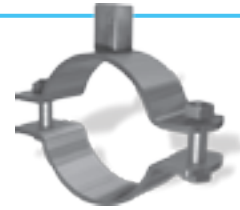

MARBLE & GRANITE FIXINGS

Stangle Cladding Fixation includes design, calculation and production of several types of mechanical fixings and accessories used for cladding purposes. Stainless and galvanized steel are among the various materials used in the fabrication.



DRY WALL & CEILING PROFILES

SFSP provides a complete product range for dry wall and ceiling constructions. Studs, Runners, Furring Channels, Ceiling Channels and Wall Angles are among the range of products produced to service the dry wall installers.



GARBAGE & LINEN CHUTES

Chutes from SFSP are very convenient, simple and low cost method of controlling and disposing of refuse and linen. Chutes meet the most stringent requirements of environmental health and safety. Chutes are used as original equipment in new buildings, such as : Hotels, Hospitals, High Rises and Residential Towers.



EXPANSION JOINTS COVERS

SFSP manufactures architectural lines of thermal, seismic, waterproof, and fire-rated expansion joint systems meeting aesthetic and structural demands of multiple projects including airports, hospitals, commercial and residential buildings, shopping malls, and several other structural types

Materials used in SFSP expansion joints systems includes 6063 Aluminum, Rubber (Natural and Neoprene), Stainless Steel, TPE.



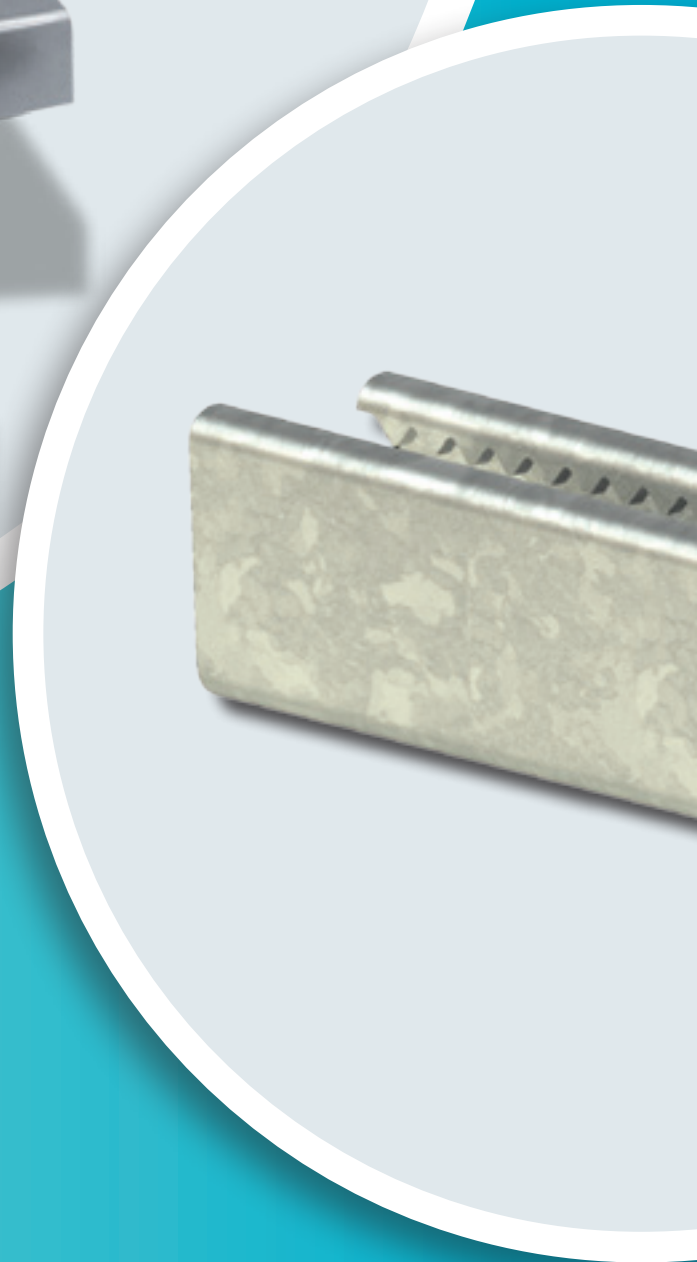



GENERAL INFORMATION

Channel

SFSP's metal framing channel is cold formed on modern rolling machines from low carbon steel manufactured according to BS 6946:1988. A continuous slot provides the ability to make attachments at any point.

Finishes

Standard Finishes: Pre-Galvanized finish (ASTM A653M coating G90 and G60). Hot Dip Galvanized after fabrication (ASTM A123 or BS EN ISO1461:2009). Other custom coatings are available upon request.

Lengths

Standard length: 3000mm with ± 3.2mm length tolerance.
Custom lengths vv available upon request.

METAL FRAMING CHANNELS

Selection Chart

Part No	Channel Dimensions		Thickness
	Height "H"	Width "W"	
CCH - 220/221	21.0 mm	41.0 mm	1.5 mm
CCH - 240/241	41.0 mm	41.0 mm	1.5 mm
CCH - 260/261	25.0 mm	50.0 mm	1.5 mm
CCH - 320/321	21.0 mm	41.0 mm	2.0 mm
CCH - 340/341	41.0 mm	41.0 mm	2.0 mm
CCH - 360/361	25.0 mm	50.0 mm	2.0 mm
CCH - 420/421	21.0 mm	41.0 mm	2.5 mm
CCH - 440/441	41.0 mm	41.0 mm	2.5 mm
CCH - 460/461	25.0 mm	50.0 mm	2.5 mm

For Toothed Channel add "T" after the Part no. ex: CCH-220T

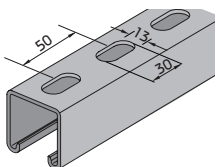
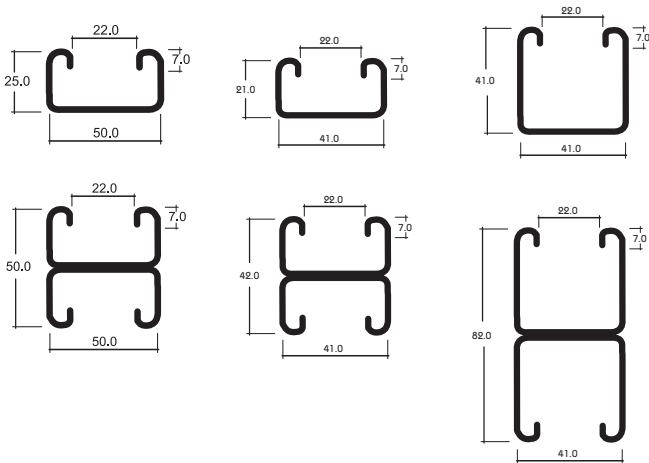
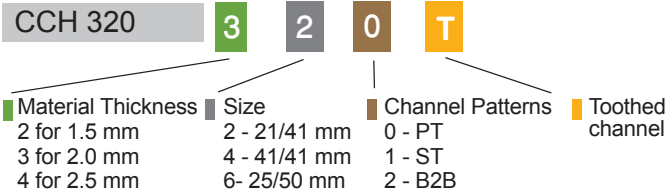

CHANNEL HOLE PATTERNS

PT Type Channel

Part No	Thick. mm.	Height "H"
CCH-220	1.5	21.0
CCH-240	1.5	41.0
CCH-260	1.5	25.0
CCH-320	2.0	21.0
CCH-340	2.0	41.0
CCH-360	2.0	25.0
CCH-420	2.5	21.0
CCH-440	2.5	41.0
CCH-460	2.5	25.0

PT Plain Type



ST Type Channel

Part No	Thick. mm.	Height "H"
CCH-221	1.5	21.0
CCH-241	1.5	41.0
CCH-261	1.5	25.0
CCH-321	2.0	21.0
CCH-341	2.0	41.0
CCH-361	2.0	25.0
CCH-421	2.5	21.0
CCH-441	2.5	41.0
CCH-461	2.5	25.0

ST Slotted Type



B2B Type Channel

Part No	Thick. mm.	Height "H"
CCH-222	1.5	42.0
CCH-242	1.5	82.0
CCH-262	1.5	50.0
CCH-322	2.0	42.0
CCH-342	2.0	82.0
CCH-362	2.0	50.0
CCH-422	2.5	42.0
CCH-442	2.5	82.0
CCH-462	2.5	50.0

B2B Type



Toothed channel type



For Toothed Channel add "T" after the Part no. ex: CCH-220T

MATERIALS

Mild Steel - Plain

A. Hot Rolled Steel Plates, Sheets and Coils S235 JR, S355 JR,

As per:

EN 10025 -2 / DIN 17100 / BS 4360 / ASTM A 1011/ ASTM A 1011-01a

JIS 3101 / JIS 3106 / GB 700 / GB / T1591.

ASTM A 907 / ASTM A 1018M.

ASTM A 570M / ASTM A 572M.

B. Cold Rolled Steel DC 01,

As per:

EN 10130 / DIN 1623, Part 2 / BS 1449:1 / ASTM A366 / ASTM A 1008 / JIS G 3141 / GB 699.

EN 10131 / ASTM A 568M



Mild Steel - Galvanized

C. Continuously Pre- Galvanized Hot-Dip Zinc Coated Steel DX 51D + Z,

As per:

EN 10327 / DIN 17162 / BS 2989/ ASTM A 527M / ASTM A 653M / JIS G 3302.

EN 10346 / EN 10326 / EN 10142 / ASTM A 526, 527, 528



D. Electro Galvanized Steel (Electrolytic Coating) DC01 + ZE,

As per:

EN 10152 / DIN 17163 / ASTM A591 / JIS G 3313 / JIS G 3141/BS 1449:1

EN 10131



AluZink Steel

E. AluZink Steel DX 51D + AZ,

As per:

EN 10215 / EN 10143/ DIN 55928 / ASTM A 792

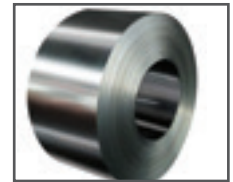

Stainless Steel

F. Austenitic Stainless Steels AISI 304 & 316,

As per:

ASTM A 240 /EN 10088-2/ DIN 17400 / BS 1449:2 /

ASTM A480 / ASTM A666 / ISO 3506 / EN 10028-7 /JIS G 4304

F.1 Stainless Steel Fasteners EN 3506

F.2 Stainless Steel Wire BS 1554 ,ASTM A276

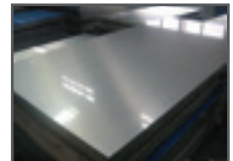

Aluminium

G. Aluminium 5052 & 6063

FINISHES

1- Hot-DIP Galvanization After Fabrication,

As per:

ASTM A 123 / ASTM A 153 / ISO 1461.

BS 729 / DIN 50976



2- Zinc Electroplating After Fabrication,

As per:

ASTM B633 / EN 2081 / EN 12329 / ISO 4042/

BS 1706 / BS 7371-12 / BS 3382 / DIN 50961







3- Powder Coating

Epoxy / Polyester / Epoxy & Polyester

BS 3900 / ISO 2409 / ISO 1519 / ISO 1520



TECHNICAL DATA

Load and Support Condition	Load Factor	Deflection Factor
Simple Beam - Uniform Load q 	1.00	1.00
Beam Fixed at Both Ends - Uniform Load 	1.50	0.30
Cantilever Beam - Uniform Load 	0.25	2.40
Continuous Beam - Two Equal Spans - Uniform Load on One Span 	1.30	0.92
Continuous Beam - Two Equal Spans Concentrated Load on Both Spans - 	1.00	0.42

EXAMPLE

Problem

Calculate the maximum allowable load and corresponding deflection of a cantilever CCH beam with a uniformly distributed load

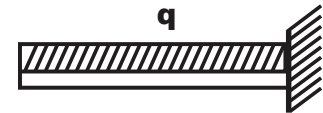







Solution

From beam load chart for CCH, maximum allowable load is q and the corresponding deflection is u . Multiplying by the appropriate factors shown in the chart above

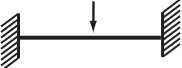
$$\text{LOAD} = q \times \text{load factor}$$

$$\text{DEFLECTION} = u \times \text{deflection factor}$$

Load and Support Condition	Load Factor	Deflection Factor
Simple Beam - Concentrated Load at Center F 	1.00	0.80
Simple Beam - Two Equal Concentrated Loads at 1/4 Points 	$\times 1.00 \ 2$	1.10
Beam Fixed at Both Ends - Concentrated Load at Center 	2.00	0.40
Cantilever Beam - Uniform Load 	0.24	3.20
Continuous Beam - Two Equal Spans Concentrated Load at Center of One Span- 	1.42	0.80
Continuous Beam - Two Equal Spans Concentrated Load at Center of Both Spans- 	$\times 1.34 \ 2$	0.50

EXAMPLE

Problem

Calculate the maximum allowable load and corresponding deflection of a simply supported CCH beam with a concentrated load at midspan as shown

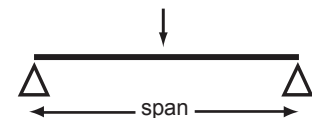

Solution

From beam load chart for CCH, maximum allowable load is F and the corresponding deflection is u . Multiplying by the appropriate factors shown in the chart above

$$\text{LOAD} = F \times \text{load factor}$$

$$\text{DEFLECTION} = u \times \text{deflection factor}$$

APPLICATIONS

HVAC Duct Support



Pipe Support



Solar Panel Support



Cable Management System Support



Catwalk



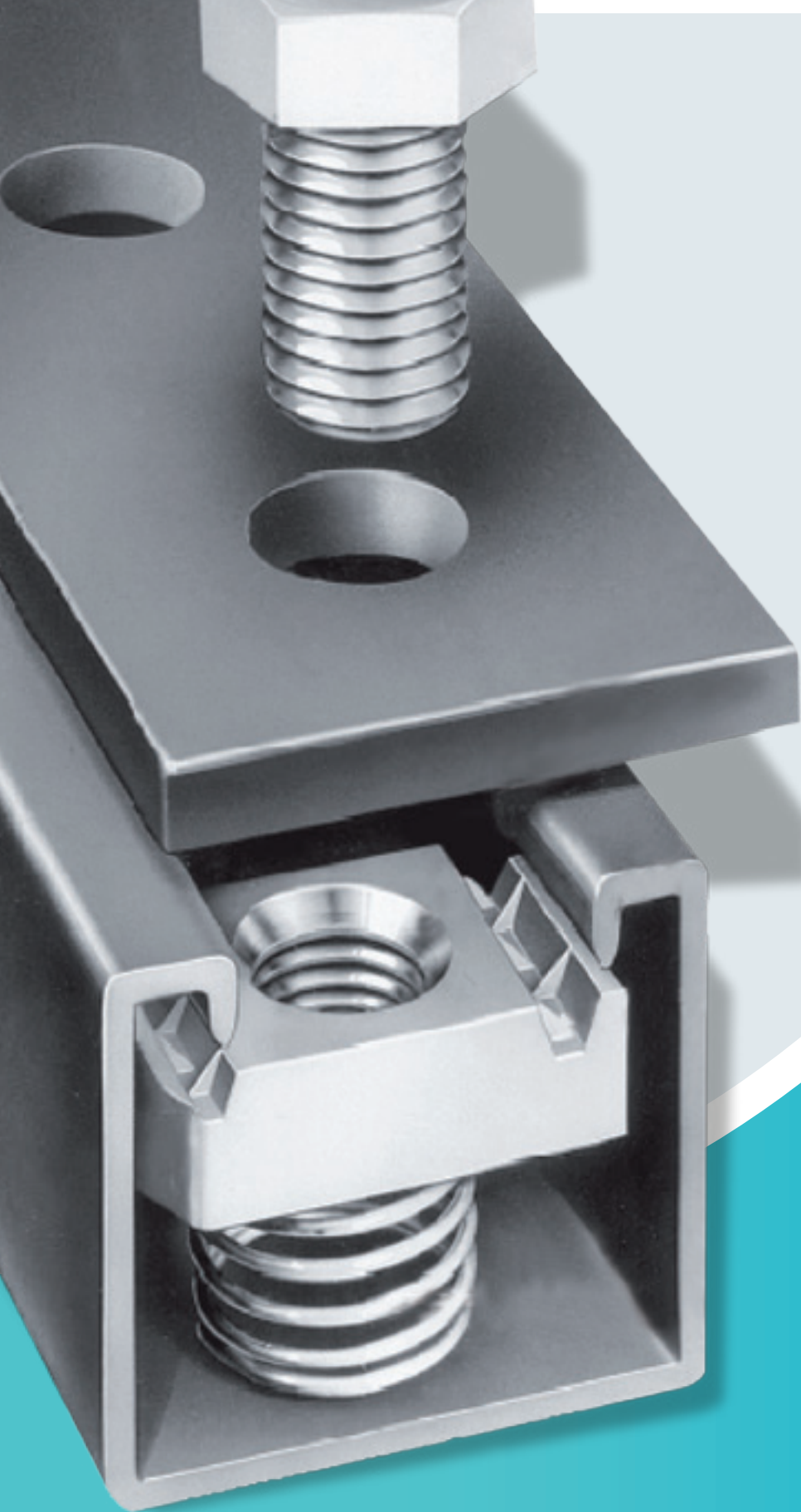

CHANNELS

Load table for single beam with uniform (characteristic) Live-Load

This associated data are considered for perforated and non-perforated c-channel types according to DIN 18.800

Thickness : 1.5 mm
 Standard Length : 3.00 m
 Finishes : Pre-Galvanized, Hot-Dip Galvanized.

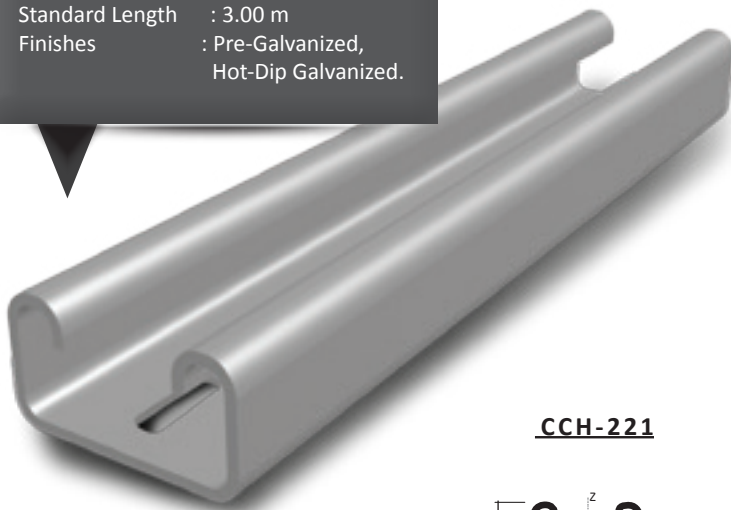

CCH-221

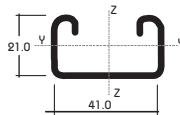

C-Channel:	41 x 21 x 1.5
Area of Shear (A_z)	0.42 cm ²
Moment of Inertia (I_y)	0.70 cm ⁴
Moment of Inertia (I_z)	3.34 cm ⁴
min. Section Modulus (S_y)	0.60 cm ³
Warping Constant (I_w)	17.49 cm ⁶
Torsional Constant (I_t)	0.01 cm ⁴
Plastic Moment cap. ($M_{pl,y}$)	0.19 kNm
Self weight (G)	0.97 kg/m

Chosen Material:	40 B = S 235 JRG2
Allowable Bending Stress	21,82 kN/cm ²
Allowable Shear Stress	12,60 kN/cm ²
Modulus of Elasticity	21.000 kN/cm ²

Beam Load Data

Span (L)	Allowable Load*		Deflection		Uniform Load* @	
					L / 360	L / 180
[cm]	q [kN/m]	F [kN]	U [mm]	[L/X]	q [kN/m]	q [kN/m]
50	2.20	0.60	1.52	330	2.00	2.20
60	1.60	0.50	2.30	260	1.20	1.60
70	1.10	0.39	2.92	240	0.73	1.14
80	0.90	0.36	4.08	200	0.49	0.87
90	0.69	0.31	5.01	180	0.34	0.69
100	0.56	0.28	6.20	160	0.25	0.50
125	0.36	0.23	9.73	130	x	0.26
150	0.25	0.19	14.01	110	x	x
175	0.18	0.16	18.69	90	x	x
200	x	x	x	x	x	x
225	x	x	x	x	x	x
250	x	x	x	x	x	x
275	x	x	x	x	x	x
300	x	x	x	x	x	x

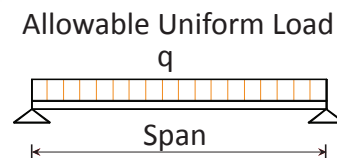
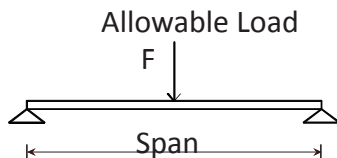

* Given loads are always "allowable characteristic live load"

BEAM LOADING GRAPH CCH-220/221

Allowable Loads

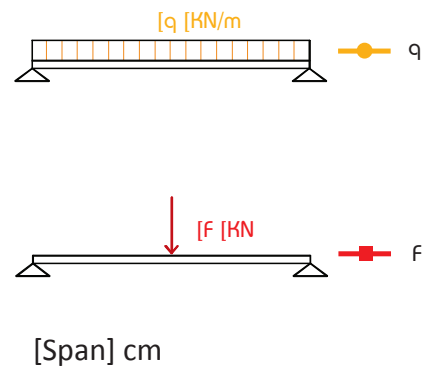
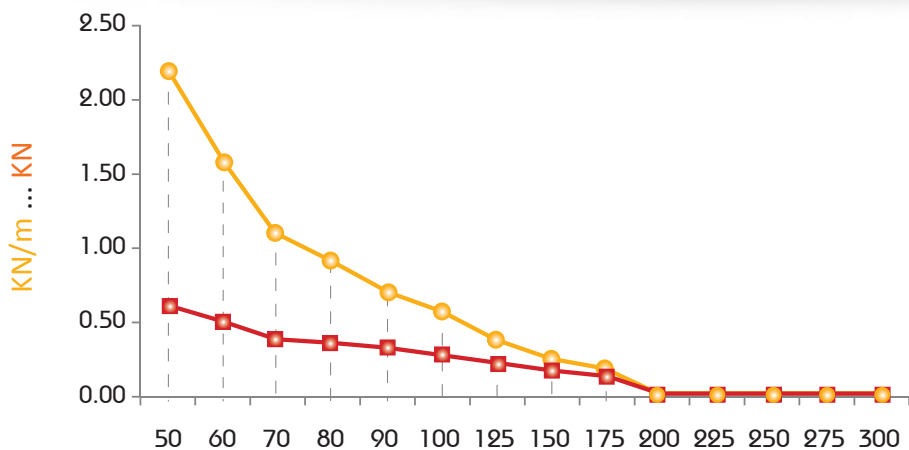

Deflection @ Allowable Uniform Load

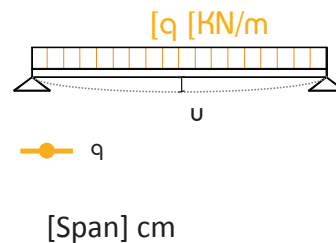
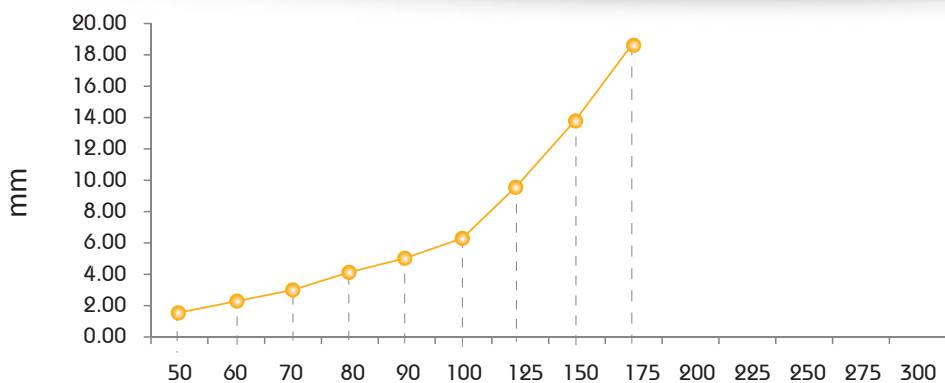

Uniform Load @ Allowable Deflection

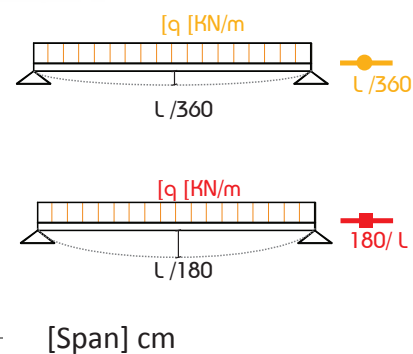
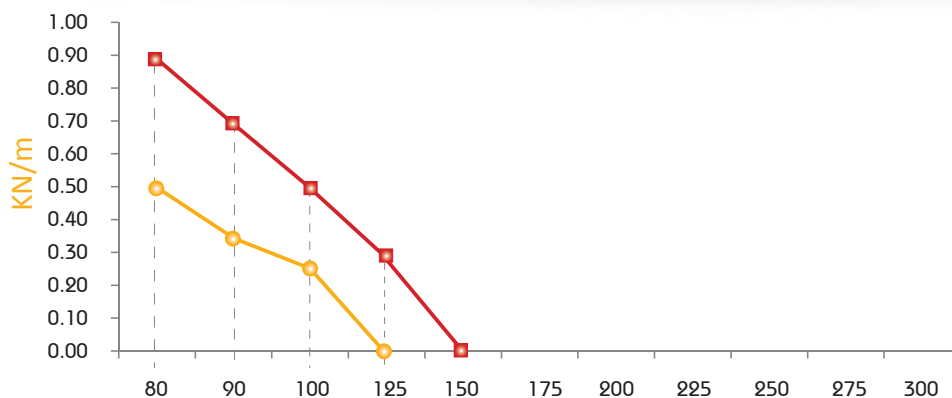

Load table for single beam with uniform (characteristic) Live-Load

This associated data are considered for perforated and non-perforated c-channel types according to DIN 18.800

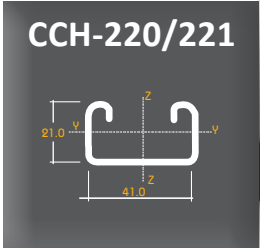

C-Channel:	41 x 21 x 1.5	
Cross Section Area (A)	0.23	cm ²
Moment of Inertia (I _y)	0.70	cm ⁴
Moment of Inertia (I _z)	3.34	cm ⁴
Self weight (G)	0.97	kg/m

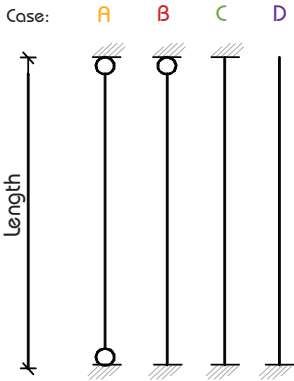

Span (L) [cm]	Allowable Central Load** [KN]			
	Case A	Case B	Case C	Case D
50	8.00	8.00	8.00	5.00
60	8.00	8.00	8.00	4.10
70	8.00	8.00	8.00	3.20
80	7.00	8.00	8.00	2.50
90	6.00	8.00	8.00	2.00
100	5.00	8.00	8.00	1.70
125	3.80	6.00	8.00	1.70
150	2.80	5.00	8.00	1.10
175	2.10	4.00	6.00	x
200	1.70	3.20	5.00	x
225	1.40	2.60	4.60	x
250	1.10	2.10	3.80	x
275	x	1.80	3.30	x
300	x	1.50	2.80	x

Column Load Data

Allowable Central ** Load

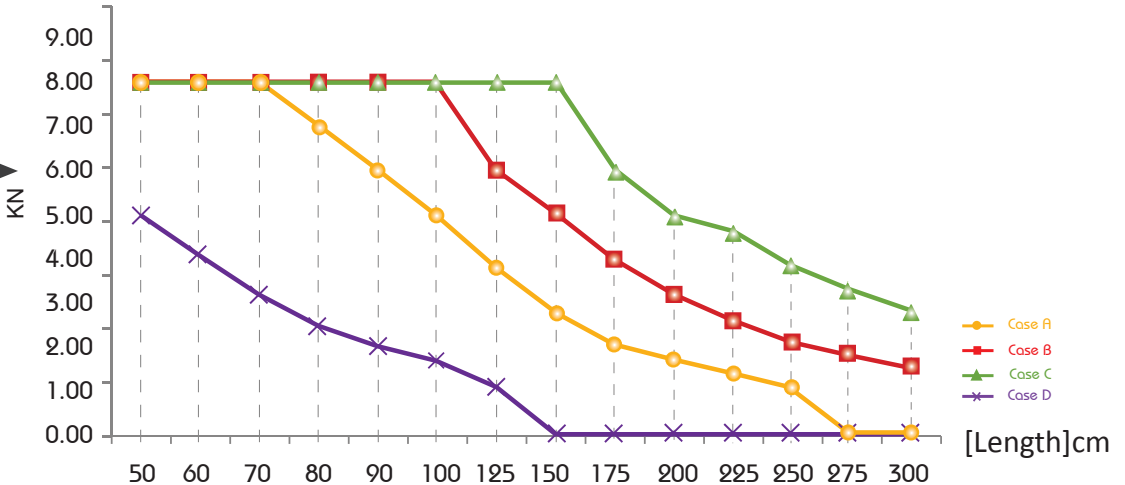

** Given loads are always "allowable characteristic live load"

Load table for single beam with uniform (characteristic) Live-Load

This associated data are considered for perforated and non-perforated c-channel types according to DIN 18.800

Thickness: 1.5 mm
 Standard Length : 3.00 m
 Finishes : Pre-Galvanized,
 Hot-Dip Galvanized.

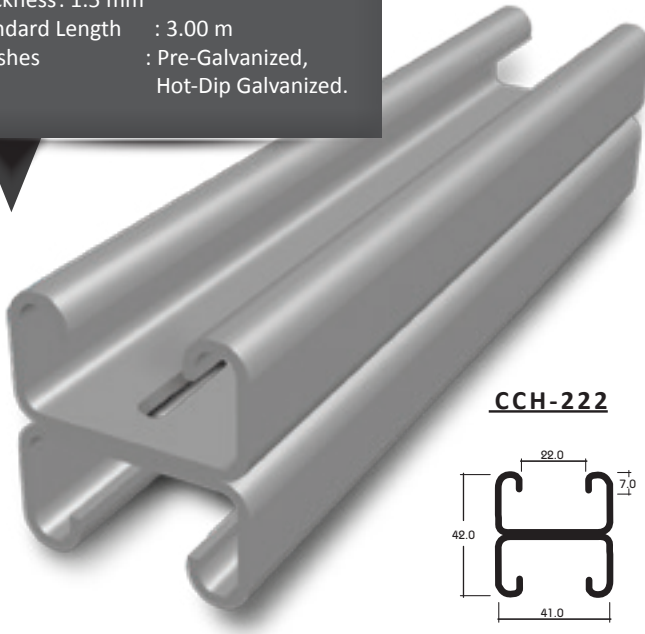

C-Channel:	41x 21x1.5 b2b	
Area of Shear (A_z)	0.54	cm ²
Moment of Inertia (I_y)	3.55	cm ⁴
Moment of Inertia (I_z)	6.69	cm ⁴
min. Section Modulus (S_y)	1.69	cm ³
Warping Constant (I_w)	16.33	cm ⁶
Torsional Constant (I_t)	0.03	cm ⁴
Plastic Moment cap. ($M_{pl,y}$)	0.50	kNm
Self weight (G)	1.94	kg/m

Chosen Material:	40 B = S 235 JRG2	
Allowable Bending Stress	21,82	kN/cm ²
Allowable Shear Stress	12,60	kN/cm ²
Modulus of Elasticity	21.000	kN/cm ²

Beam Load Data

Span (L) [cm]	Allowable Load*		Deflection U [mm]	[L / X]	Uniform Load* @	
	q [kN/m]	F [kN]			L / 360 q [kN/m]	L / 180 q [kN/m]
50	6.30	1.60	0.86	580	6.30	6.30
60	4.40	1.30	1.24	480	4.40	4.40
70	3.20	1.10	1.68	420	3.20	3.20
80	2.50	1.00	2.24	360	2.50	2.50
90	1.90	0.90	2.72	330	1.70	1.90
100	1.60	0.80	3.49	290	1.30	1.60
125	1.00	0.60	5.33	230	0.70	1.00
150	0.70	0.50	7.74	190	0.40	0.70
175	0.51	0.40	10.44	170	0.20	0.50
200	0.39	0.39	13.62	150	x	0.32
225	0.31	0.35	17.35	130	x	0.22
250	0.25	0.31	21.32	120	x	0.16
275	0.21	0.29	26.22	100	x	x
300	0.17	0.26	30.06	100	x	x

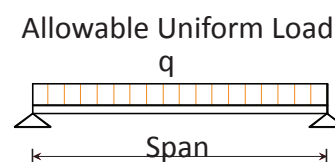
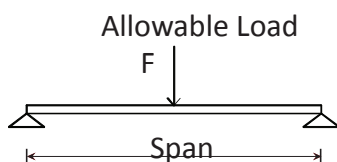

* Given loads are always "allowable characteristic live load"

BEAM LOADING GRAPH CCH-222

Allowable Loads

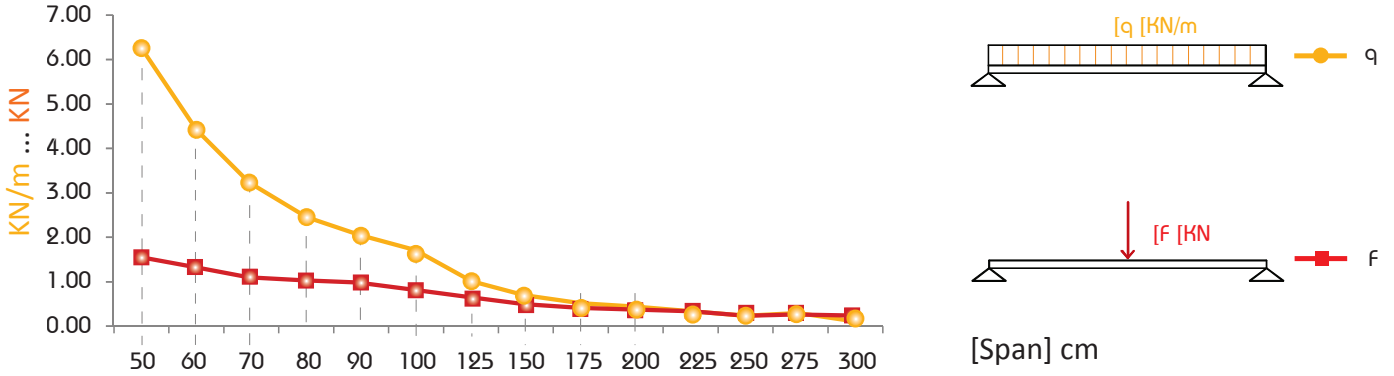

Deflection @ Allowable Uniform Load

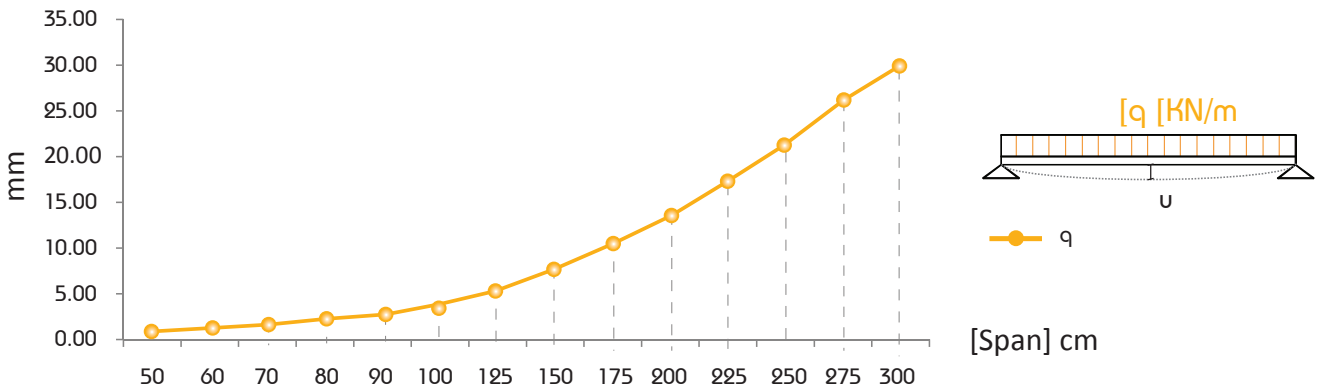

Uniform Load @ Allowable Deflection

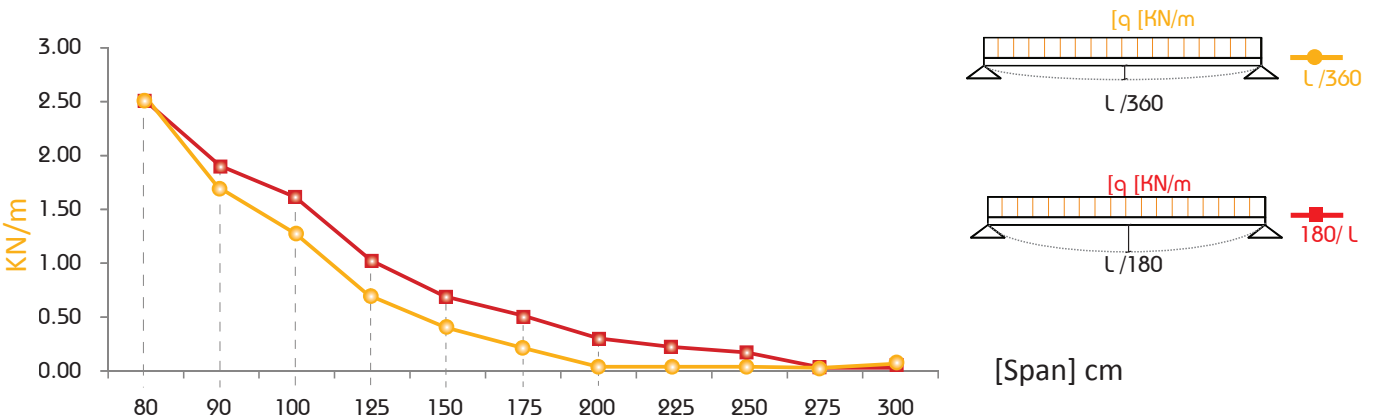

Load table for single beam with uniform (characteristic) Live-Load

This associated data are considered for perforated and non-perforated c-channel types according to DIN 18.800

C-Channel:	41 x 21 x 1.5 b2b	
Cross Section Area (A)	2.47	cm ²
Moment of Inertia (I _y)	3.55	cm ⁴
Moment of Inertia (I _z)	6.69	cm ⁴
Self weight (G)	1.94	kg/m

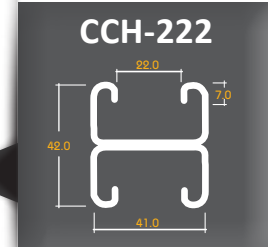

Span (L) [cm]	Allowable Central Load** [KN]			
	Case A	Case B	Case C	Case D
50	16.00	16.00	16.00	16.00
60	16.00	16.00	16.00	16.00
70	16.00	16.00	16.00	13.00
80	16.00	16.00	16.00	10.00
90	16.00	16.00	16.00	9.00
100	16.00	16.00	16.00	7.00
125	15.00	16.00	16.00	5.00
150	11.00	16.00	16.00	3.70
175	9.00	15.00	16.00	2.80
200	7.00	13.00	16.00	2.20
225	6.00	11.00	16.00	x
250	5.00	9.00	15.00	x
275	4.40	8.00	13.00	x
300	3.70	7.00	11.00	x

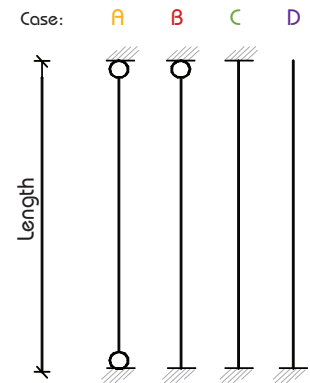

Column Load Data

Allowable Central Load**

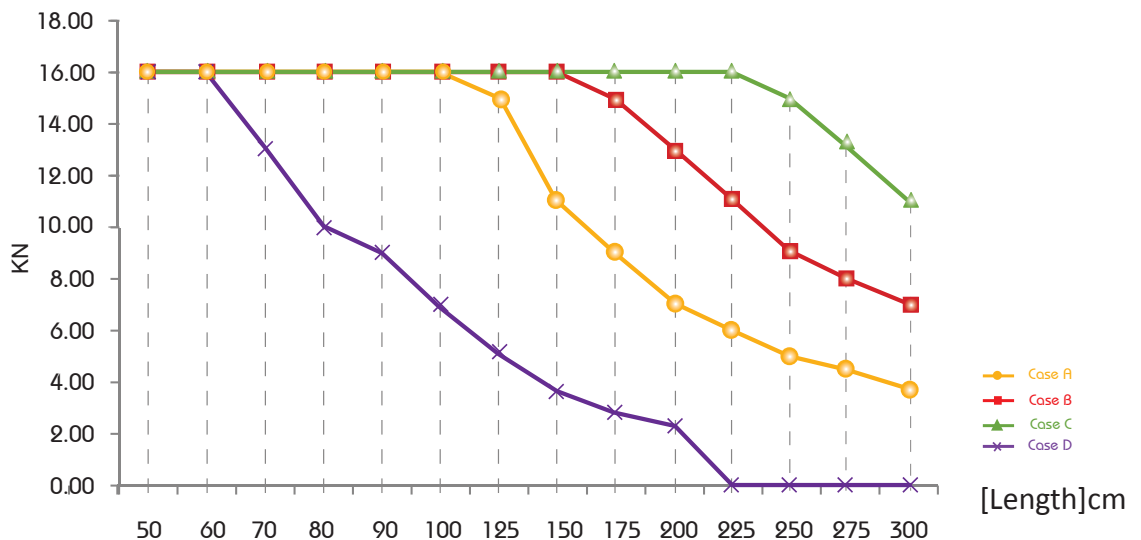

** Given loads are always "allowable characteristic live load"

CCH-240/241

Load table for single beam with uniform (characteristic) Live-Load

This associated data are considered for perforated and non-perforated c-channel types according to DIN 18.800

Thickness : 1.5 mm
 Standard Length : 3.00 m
 Finishes : Pre-Galvanized,
 Hot-Dip Galvanized.

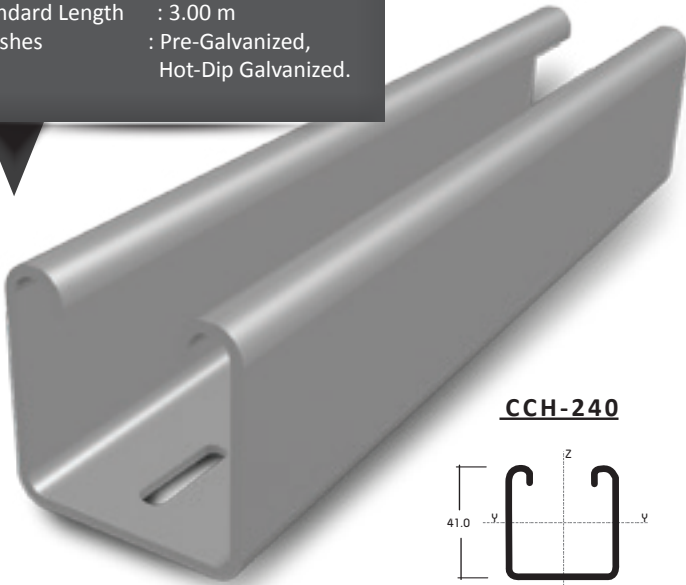

C-Channel:	41x41x1.5	
Area of Shear (A_z)	1.02	cm ²
Moment of Inertia (I_y)	3.87	cm ⁴
Moment of Inertia (I_z)	5.68	cm ⁴
min. Section Modulus (S_y)	1.76	cm ³
Warping Constant (I_w)	114.17	cm ⁶
Torsional Constant (I_t)	0.02	cm ⁴
Plastic Moment cap. (M_{ply})	0.52	kNm
Self weight (G)	1.44	kg/m

Chosen Material:	40 B = S 235 JRG2	
Allowable Bending Stress	21,82	kN/cm ²
Allowable Shear Stress	12,60	kN/cm ²
Modulus of Elasticity	21.000	kN/cm ²

Beam Load Data

Span (L)	Allowable Load*		Deflection		Uniform Load* @	
					L / 360	L / 180
[cm]	q [kN/m]	F [kN]	U [mm]	[L/X]	q [kN/m]	q [kN/m]
50	6.60	1.70	0.83	610	6.60	6.60
60	4.60	1.40	1.19	500	4.60	4.60
70	3.30	1.20	1.59	440	3.30	3.30
80	2.60	1.00	2.13	380	2.60	2.60
90	2.00	0.90	2.63	340	1.90	2.00
100	1.60	0.80	3.20	310	1.40	1.60
125	1.00	0.60	4.89	260	0.70	1.00
150	0.73	0.50	7.40	200	0.40	0.70
175	0.53	0.50	9.96	180	0.30	0.50
200	0.41	0.40	13.14	150	0.20	0.30
225	0.32	0.36	16.42	140	x	0.24
250	0.26	0.33	20.34	120	x	0.18
275	0.22	0.30	25.20	110	x	x
300	0.18	0.27	29.20	100	x	x

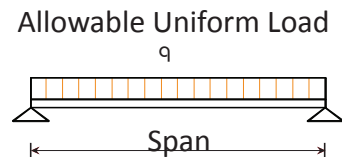
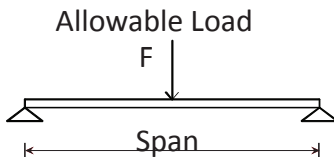

* Given loads are always "allowable characteristic live load"

BEAM LOADING GRAPH CCH-240/241

Allowable Loads

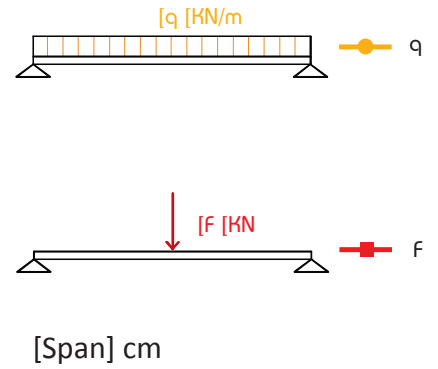
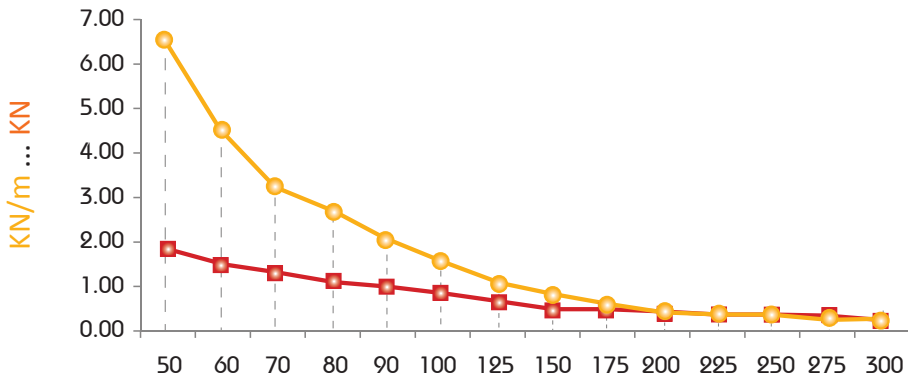

Deflection @ Allowable Uniform Load

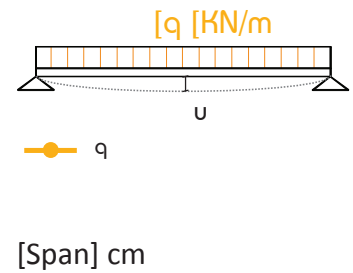
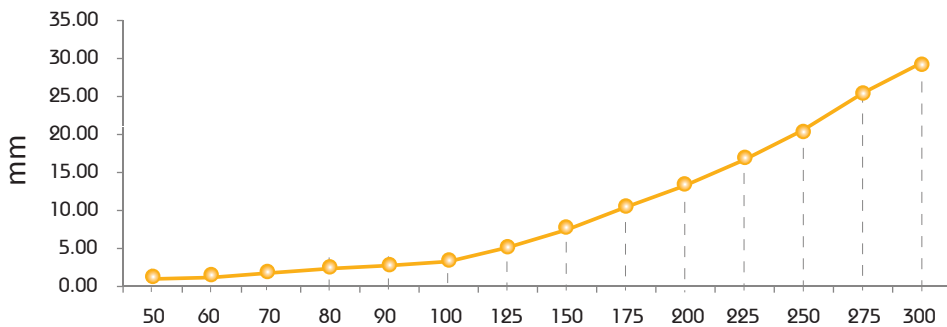

Uniform Load @ Allowable Deflection

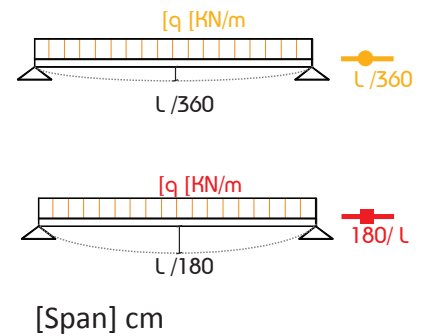
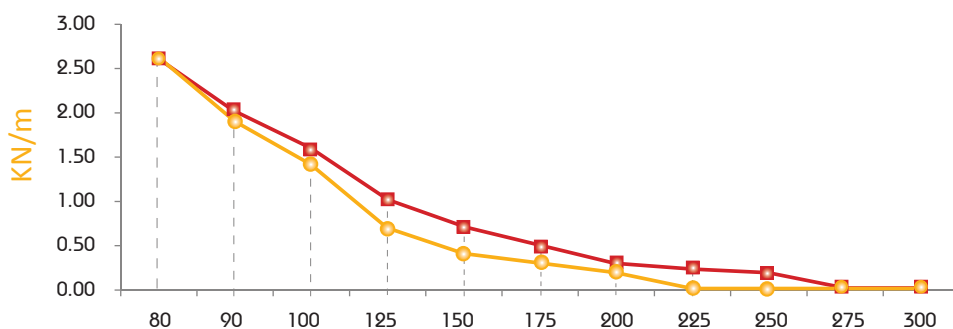

Load table for single beam with uniform (characteristic) Live-Load

This associated data are considered for perforated and non-perforated c-channel types according to DIN 18.800

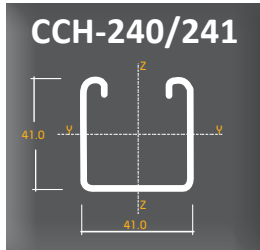

C-Channel:	41 x 41 x 1.5	
Cross Section Area (A)	1.83	cm ²
Moment of Inertia (I _y)	3.87	cm ⁴
Moment of Inertia (I _z)	5.68	cm ⁴
Self weight (G)	1.44	kg/m

Span (L) [cm]	Allowable Central Load** [kN]			
	Case A	Case B	Case C	Case D
50	12.00	12.00	12.00	12.00
60	12.00	12.00	12.00	12.00
70	12.00	12.00	12.00	12.00
80	12.00	12.00	12.00	10.00
90	12.00	12.00	12.00	8.00
100	12.00	12.00	12.00	7.00
125	12.00	12.00	12.00	5.00
150	11.00	12.00	12.00	3.90
175	9.00	12.00	12.00	3.00
200	7.00	12.00	12.00	2.30
225	6.00	10.00	12.00	1.90
250	5.00	9.00	12.00	x
275	4.60	8.00	12.00	x
300	3.90	7.00	11.00	x

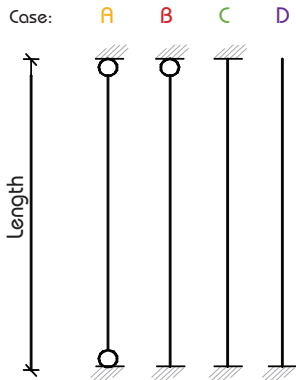

Column Load Data

Allowable Central Load**

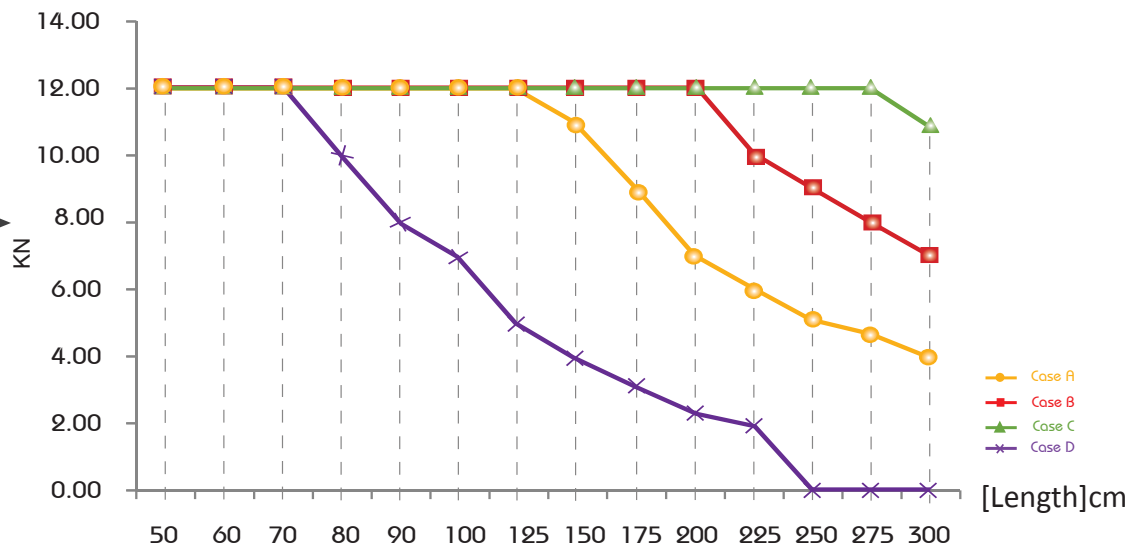

** Given loads are always "allowable characteristic live load"

Load table for single beam with uniform (characteristic) Live-Load

This associated data are considered for perforated and non-perforated c-channel types according to DIN 18.800

Thickness : 1.5 mm
 Standard Length : 3.00 m
 Finishes : Pre-Galvanized,
 Hot-Dip Galvanized.

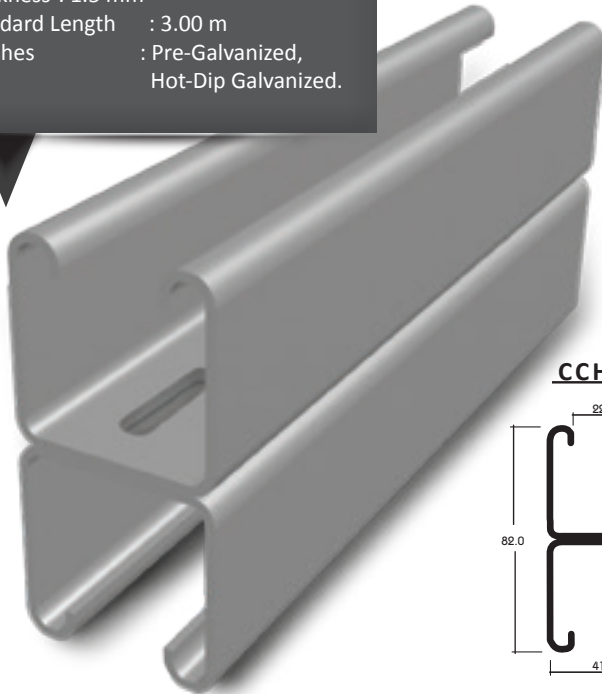

C-Channel:	41x 41x1.5 b2b	
Area of Shear (A_z)	1.43	cm ²
Moment of Inertia (I_y)	21.11	cm ⁴
Moment of Inertia (I_z)	11.37	cm ⁴
min. Section Modulus (S_y)	5.15	cm ³
Warping Constant (I_w)	95.85	cm ⁶
Torsional Constant (I_t)	0.04	cm ⁴
Plastic Moment cap. ($M_{pl,y}$)	1.53	kNm
Self weight (G)	2.88	kg/m

Chosen Material:	40 B = S 235 JRG2	
Allowable Bending Stress	21,82	kN/cm ²
Allowable Shear Stress	12,60	kN/cm ²
Modulus of Elasticity	21.000	kN/cm ²

Beam Load Data

Span (L) [cm]	Allowable Load*		Deflection U [mm]	[L / X]	Uniform Load* @	
	q [kN/m]	F [kN]			L / 360 q [kN/m]	L / 180 q [kN/m]
50	19.20	4.80	0.44	1.130	19.20	19.20
60	13.30	4.00	0.63	950	13.30	13.30
70	9.80	3.40	0.86	810	9.80	9.80
80	7.50	3.00	1.13	710	7.50	7.50
90	5.90	2.70	1.42	630	5.90	5.90
100	4.80	2.40	1.76	570	4.80	4.80
125	3.10	1.90	2.78	450	3.10	3.10
150	2.10	1.60	3.90	380	2.10	2.10
175	1.60	1.40	5.51	320	1.40	1.60
200	1.10	1.10	6.46	310	0.90	1.10
225	0.80	0.90	7.53	300	0.70	0.80
250	0.58	0.70	8.32	300	0.50	0.60
275	0.44	0.60	9.24	300	0.40	0.40
300	0.34	0.50	10.11	300	0.30	0.30

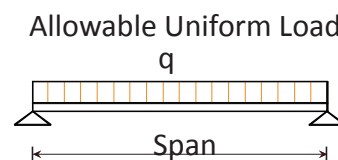
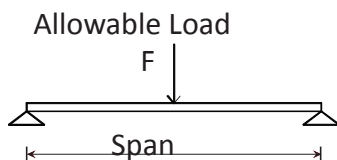

* Given loads are always "allowable characteristic live load"

BEAM LOADING GRAPH CCH-242

Allowable Loads

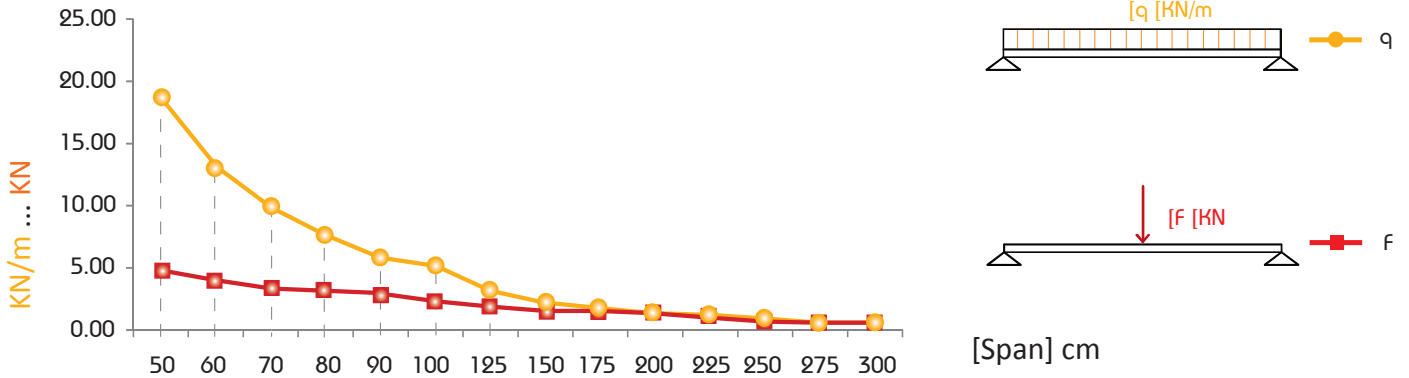

Deflection @ Allowable Uniform Load

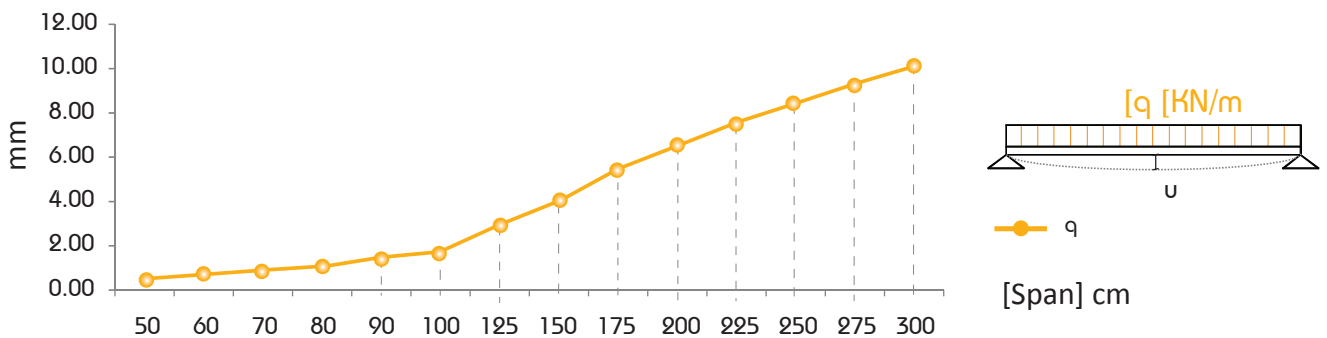

Uniform Load @ Allowable Deflection

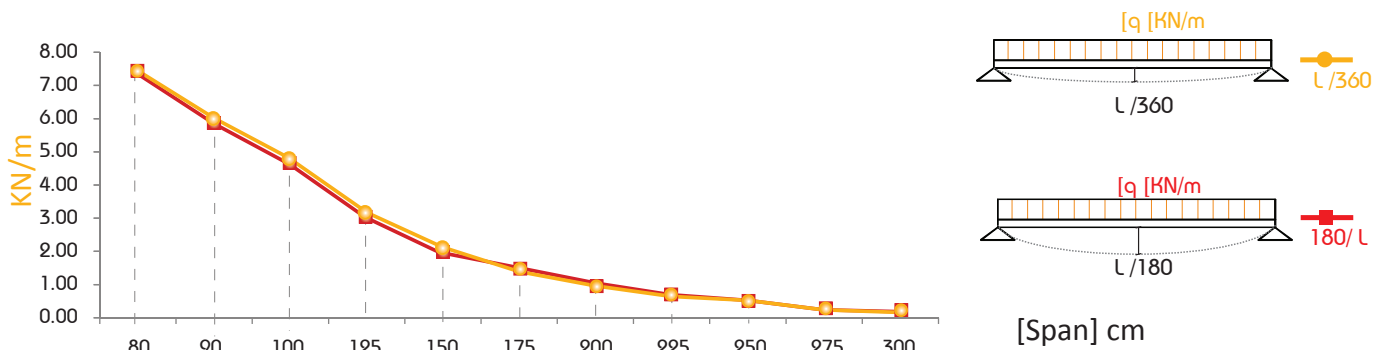

Load table for single beam with uniform (characteristic) Live-Load

This associated data are considered for perforated and non-perforated c-channel types according to DIN 18.800

C-Channel:	41 x 41 x 1.5 b2b	
Cross Section Area (A)	3.67	cm ²
Moment of Inertia (I _y)	21.11	cm ⁴
Moment of Inertia (I _z)	11.37	cm ⁴
Self weight (G)	2.88	kg/m

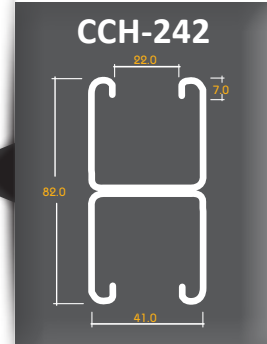

Span (L) [cm]	Allowable Central Load** [KN]			
	Case A	Case B	Case C	Case D
50	24.00	24.00	24.00	24.00
60	24.00	24.00	24.00	24.00
70	24.00	24.00	24.00	24.00
80	24.00	24.00	24.00	24.00
90	24.00	24.00	24.00	23.00
100	24.00	24.00	24.00	20.00
125	24.00	24.00	24.00	14.00
150	24.00	24.00	24.00	10.00
175	24.00	24.00	24.00	8.00
200	20.00	24.00	24.00	6.00
225	17.00	24.00	24.00	5.00
250	14.00	24.00	24.00	4.40
275	12.00	21.00	24.00	3.70
300	10.00	19.00	24.00	x

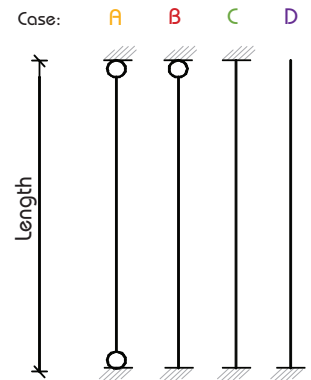

Column Load Data

Allowable Central Load

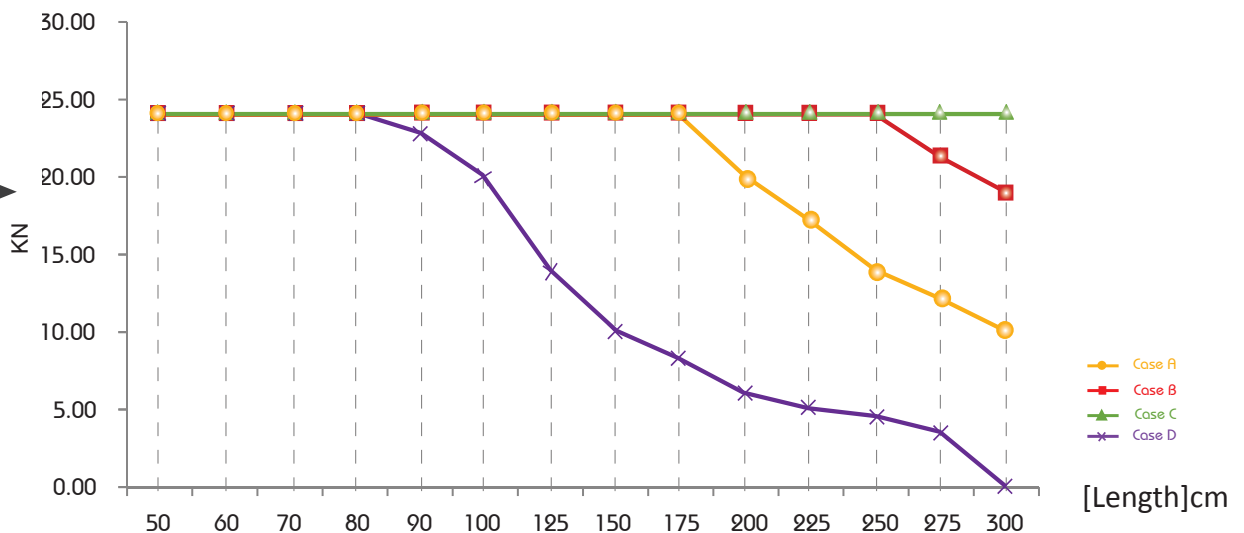

** Given loads are always "allowable characteristic live load"

Load table for single beam with uniform (characteristic) Live-Load

This associated data are considered for perforated and non-perforated c-channel types according to DIN 18.800

Thickness : 1.5 mm
 Standard Length : 3.00 m
 Finishes : Pre-Galvanized, Hot-Dip Galvanized.



C-Channel:	50 x 25 x 1.5	
Area of Shear (A_z)	0.52	cm ²
Moment of Inertia (I_y)	1.19	cm ⁴
Moment of Inertia (I_z)	6.13	cm ⁴
min. Section Modulus (S_y)	0.83	cm ³
Warping Constant (I_w)	40.86	cm ⁶
Torsional Constant (I_t)	0.01	cm ⁴
Plastic Moment cap. ($M_{pl,y}$)	0.26	kNm
Self weight (G)	1.20	kg/m

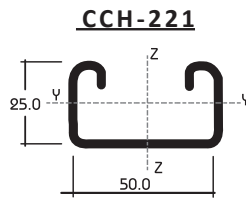

Chosen Material:	S 235 JRG2	
Allowable Bending Stress	21,82	kN/cm ²
Allowable Shear Stress	12,60	kN/cm ²
Modulus of Elasticity	21.000	kN/cm ²

Beam Load Data

Span (L)	Allowable Load*		Deflection		Uniform Load* @	
					L / 360	L / 180
[cm]	q [kN/m]	F [kN]	U [mm]	[L/X]	q [kN/m]	q [kN/m]
30	8.60	1.30	0.40	750	8.60	8.60
40	4.80	1.00	0.71	570	4.80	4.80
50	3.10	0.78	1.11	450	3.09	3.09
60	2.10	0.63	1.57	380	1.97	2.15
70	1.60	0.56	2.22	320	1.24	1.58
80	1.20	0.48	2.85	280	0.83	1.21
90	1.00	0.45	3.81	240	0.59	0.95
100	0.77	0.39	4.48	220	0.43	0.77
125	0.49	0.31	7.02	180	0.22	0.44
150	0.34	0.26	10.21	150	x	0.25
175	0.25	0.22	14.08	120	x	x
200	0.19	0.19	18.52	110	x	x
225	x	x	x	x	x	x
250	x	x	x	x	x	x
275	x	x	x	x	x	x
300	x	x	x	x	x	x

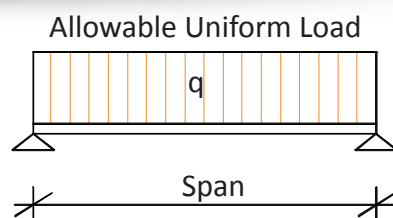
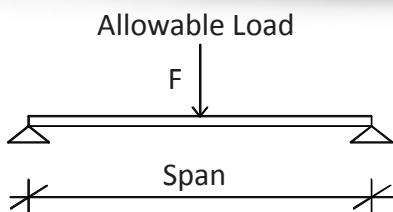

* Given loads are always "allowable characteristic live load"

BEAM LOADING GRAPH CCH-260/261

Allowable Loads

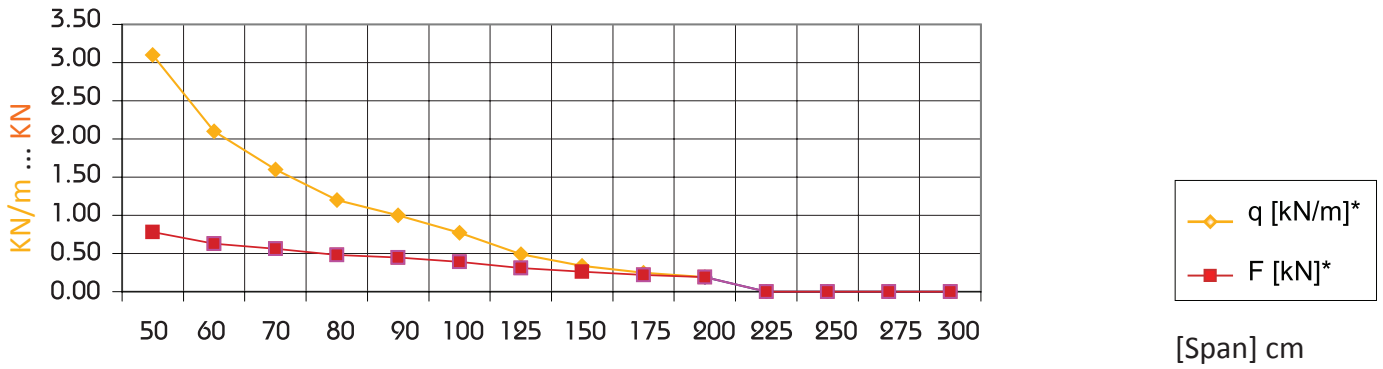

Deflection @ Allowable Uniform Load

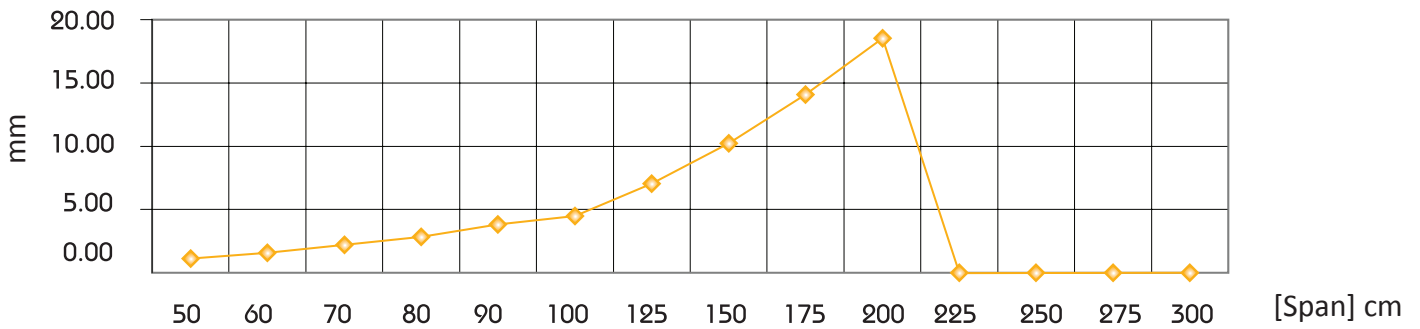

Uniform Load @ Allowable Deflection

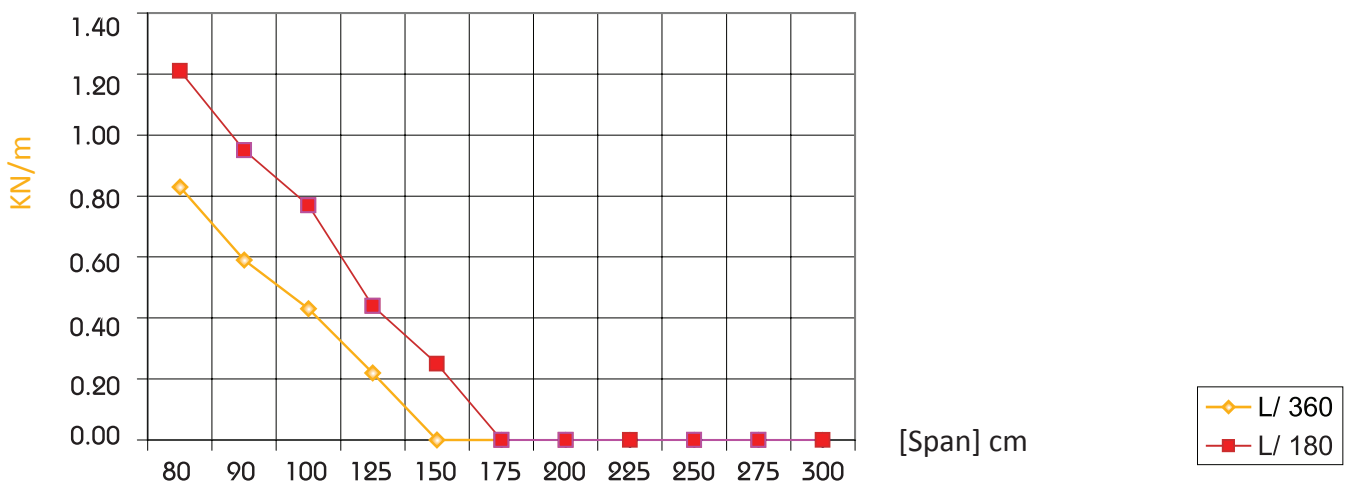

Load table for single beam with uniform (characteristic) Live-Load

This associated data are considered for perforated and non-perforated c-channel types according to DIN 18.800

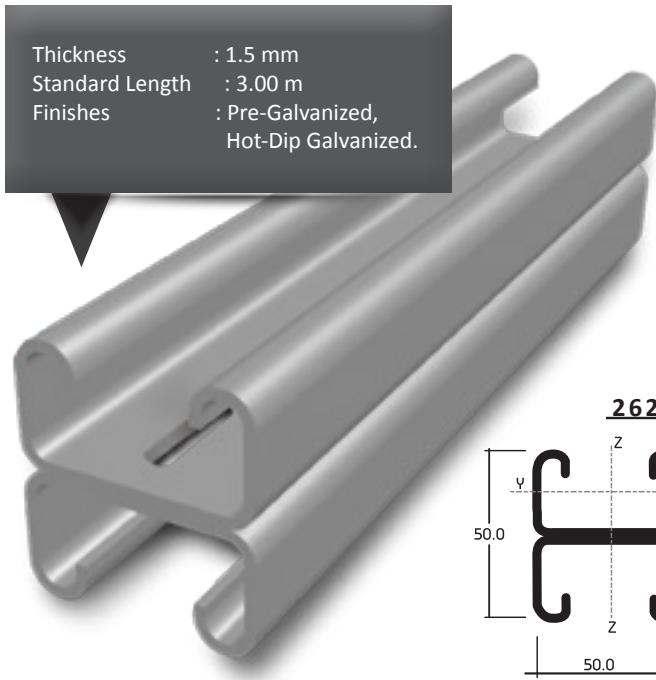

C-Channel:	50 x 25 x 1.5 b2b	
Area of Shear (A_z)	1.05	cm ²
Moment of Inertia (I_y)	5.63	cm ⁴
Moment of Inertia (I_z)	12.27	cm ⁴
min. Section Modulus (S_y)	2.25	cm ³
Warping Constant (I_w)	25.85	cm ⁶
Torsional Constant (I_t)	0.03	cm ⁴
Plastic Moment cap. ($M_{pl,y}$)	0.67	kNm
Self weight (G)	2.30	kg/m

Chosen Material:	S 235 JRG2	
Allowable Bending Stress	21,82	kN/cm ²
Allowable Shear Stress	12,60	kN/cm ²
Modulus of Elasticity	21.000	kN/cm ²

Beam Load Data

Span (L) [cm]	Allowable Load* q [kN/m] F [kN]		Deflection U [mm] [L/X]		Uniform Load* @	
					L / 360 q [kN/m]	L / 180 q [kN/m]
50	8,40	2,10	0,64	780	8,40	8,40
60	5,80	1,70	0,91	660	5,80	5,80
70	4,30	1,50	1,26	560	4,30	4,30
80	3,30	1,30	1,65	490	3,30	3,30
90	2,60	1,20	2,08	430	2,60	2,60
100	2,10	1,10	2,57	390	2,00	2,10
125	1,30	0,80	3,91	320	1,00	1,30
150	0,90	0,68	5,66	260	0,60	0,93
175	0,68	0,60	7,99	220	0,38	0,68
200	0,52	0,52	10,53	190	0,25	0,50
225	0,41	0,46	13,44	170	0,18	0,35
250	0,34	0,43	17,18	150	x	0,26
275	0,28	0,39	20,99	130	x	0,19
300	0,23	0,35	24,83	120	x	x

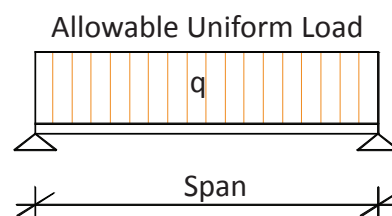
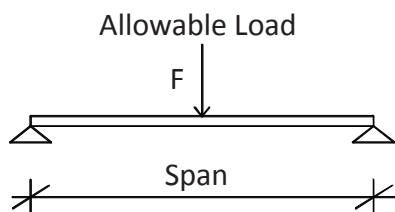

* Given loads are always "allowable characteristic live load"

BEAM LOADING GRAPH CCH-262

Allowable Loads

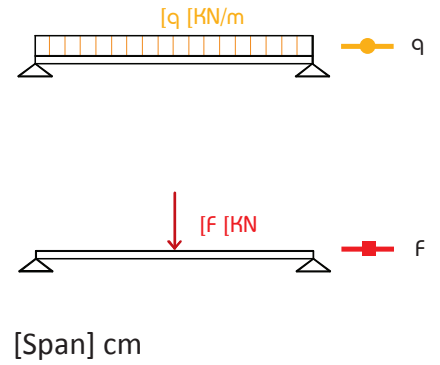
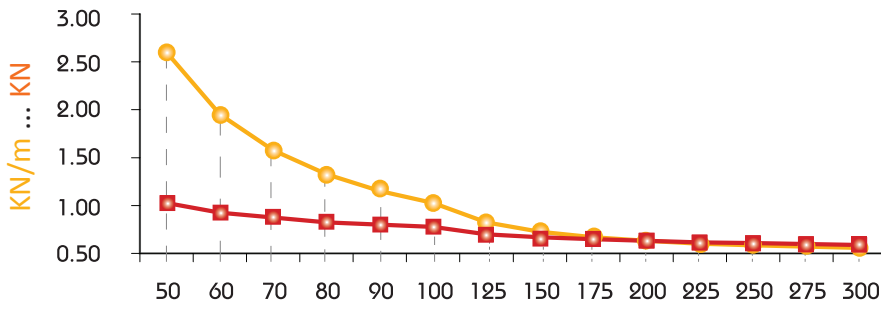

Deflection @ Allowable Uniform Load

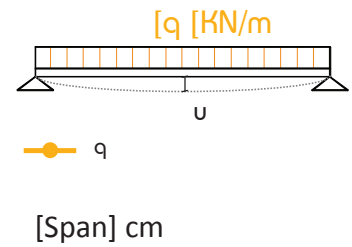
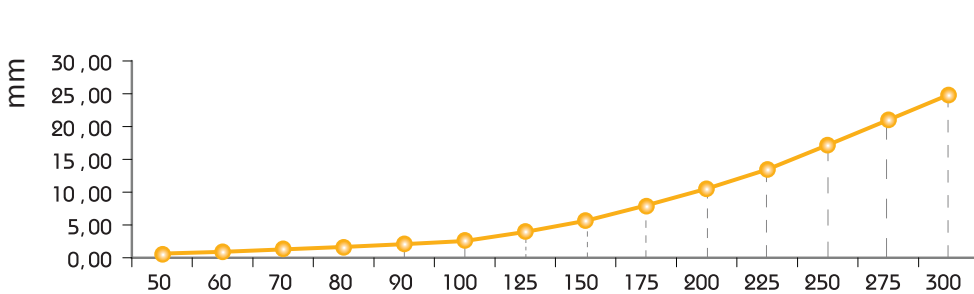

Uniform Load @ Allowable Deflection

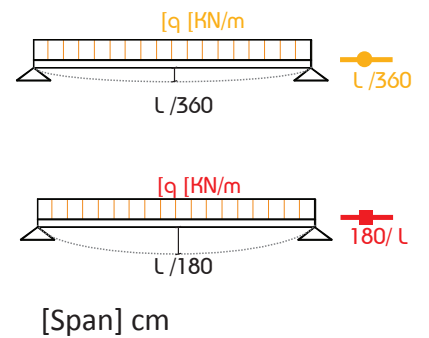
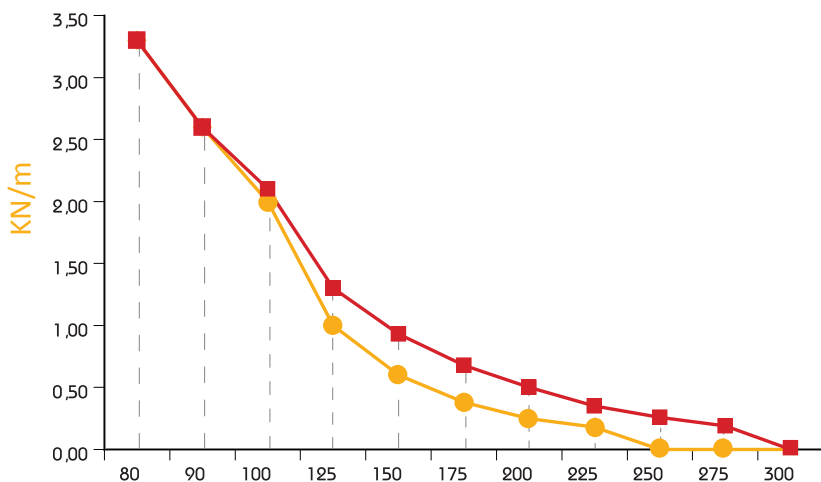

CCH-320/321

Load table for single beam with uniform (characteristic) Live-Load

This associated data are considered for perforated and non-perforated c-channel types according to DIN 18.800

Thickness : 2.0 mm
 Standard Length : 3.00 m
 Finishes : Pre-Galvanized, Hot-Dip Galvanized.

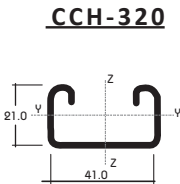

C-Channel:	41 x 21 x 2.0	
Area of Shear (A_z)	0.55	cm ²
Moment of Inertia (I_y)	0.88	cm ⁴
Moment of Inertia (I_z)	4.25	cm ⁴
min. Section Modulus (S_y)	0.75	cm ³
Warping Constant (I_w)	21.34	cm ⁶
Torsional Constant (I_t)	0.02	cm ⁴
Plastic Moment cap. ($M_{pl,y}$)	0.24	kNm
Self weight (G)	1.27	kg/m

Chosen Material:	40 B = S 235 JRG2	
Allowable Bending Stress	21,82	kN/cm ²
Allowable Shear Stress	12,60	kN/cm ²
Modulus of Elasticity	21.000	kN/cm ²

Beam Load Data

Span (L)	Allowable Load*		Deflection		Uniform Load* @	
					L / 360	L / 180
[cm]	q [kN/m]	F [kN]	U [mm]	[L/X]	q [kN/m]	q [kN/m]
50	2.80	0.70	1.54	320	2.50	2.80
60	1.90	0.60	2.17	280	1.50	1.90
70	1.40	0.50	2.96	240	0.90	1.40
80	1.10	0.40	3.97	200	0.60	1.10
90	0.90	0.41	5.20	170	0.43	0.86
100	0.70	0.35	6.17	160	0.32	0.63
125	0.45	0.28	9.68	130	0.16	0.32
150	0.31	0.23	13.82	110	x	0.19
175	0.23	0.20	19.00	90	x	x
200	0.17	0.17	23.96	80	x	x
225	x	x	x	x	x	x
250	x	x	x	x	x	x
275	x	x	x	x	x	x
300	x	x	x	x	x	x

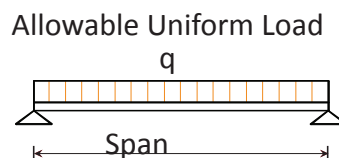
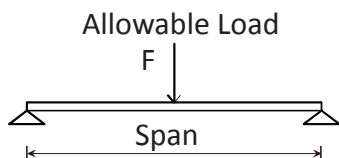

* Given loads are always "allowable characteristic live load"

BEAM LOADING GRAPH CCH-320/321

Allowable Loads

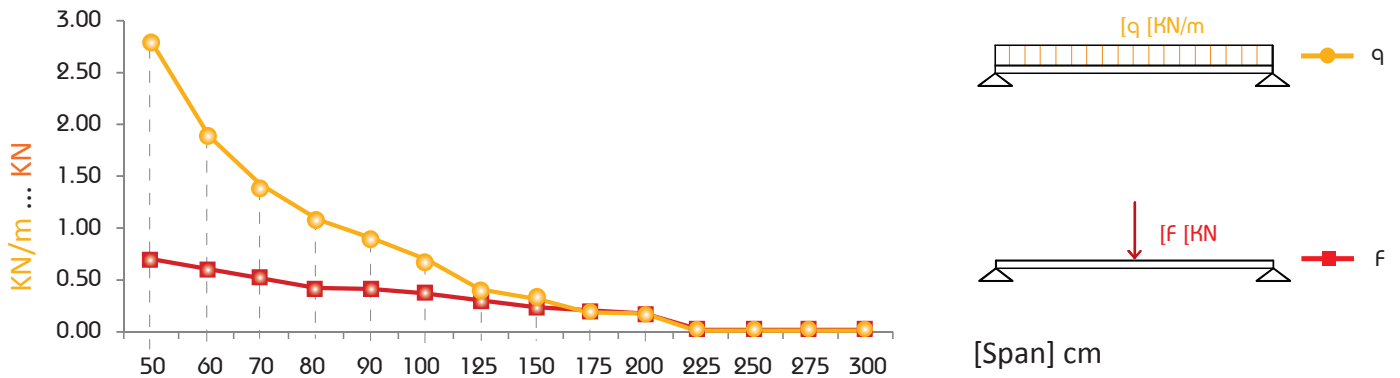

Deflection @ Allowable Uniform Load

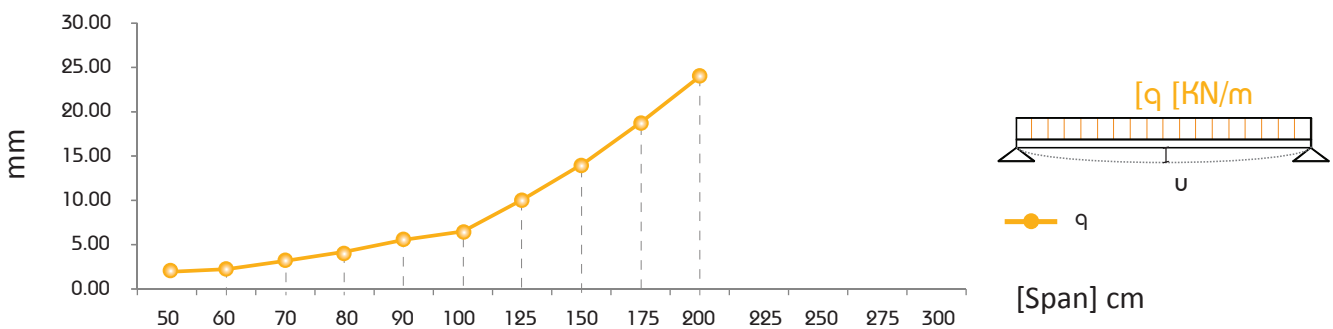

Uniform Load @ Allowable Deflection

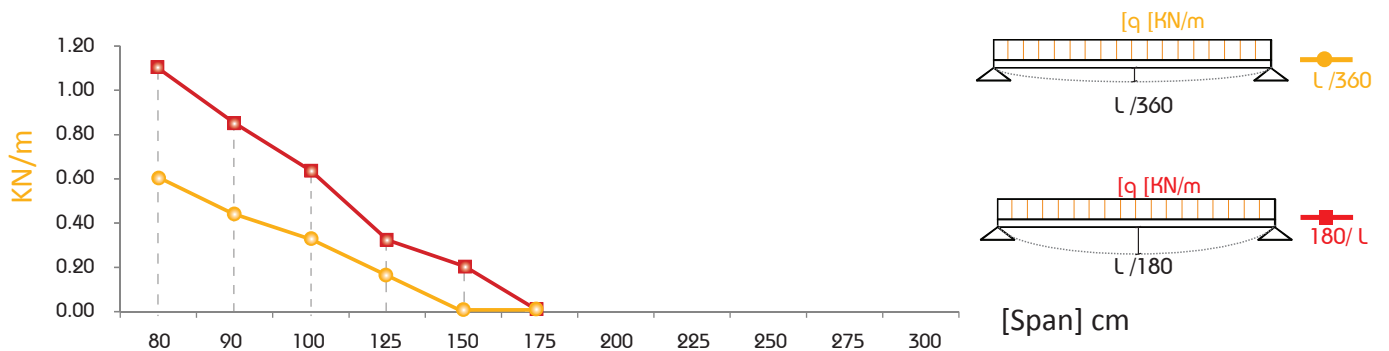

Load table for single beam with uniform (characteristic) Live-Load

This associated data are considered for perforated and non-perforated c-channel types according to DIN 18.800

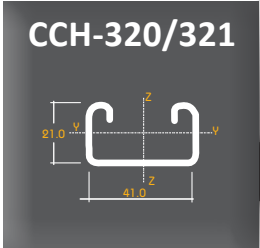

C-Channel:	41 x 21 x 2.0	
Cross Section Area (A)	1.62	cm ²
Moment of Inertia (I _y)	0.88	cm ⁴
Moment of Inertia (I _z)	4.25	cm ⁴
Self weight (G)	1.27	kg/m

Span (L) [cm]	Allowable Central Load** [KN]			
	Case A	Case B	Case C	Case D
50	10.00	10.00	10.00	6.00
60	10.00	10.00	10.00	5.00
70	10.00	10.00	10.00	4.00
80	9.00	10.00	10.00	3.20
90	8.00	10.00	10.00	2.60
100	6.00	10.00	10.00	2.10
125	4.90	8.00	10.00	1.40
150	3.60	6.00	10.00	x
175	2.70	5.00	8.00	x
200	2.10	4.00	6.00	x
225	1.70	3.30	5.00	x
250	1.40	2.70	4.90	x
275	x	2.30	4.10	x
300	x	1.90	3.60	x

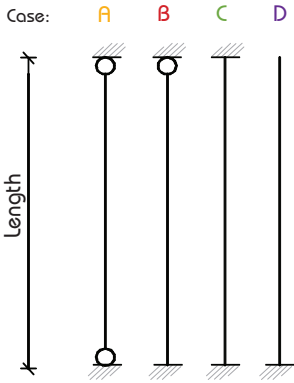

Column Load Data

Allowable Central Load**

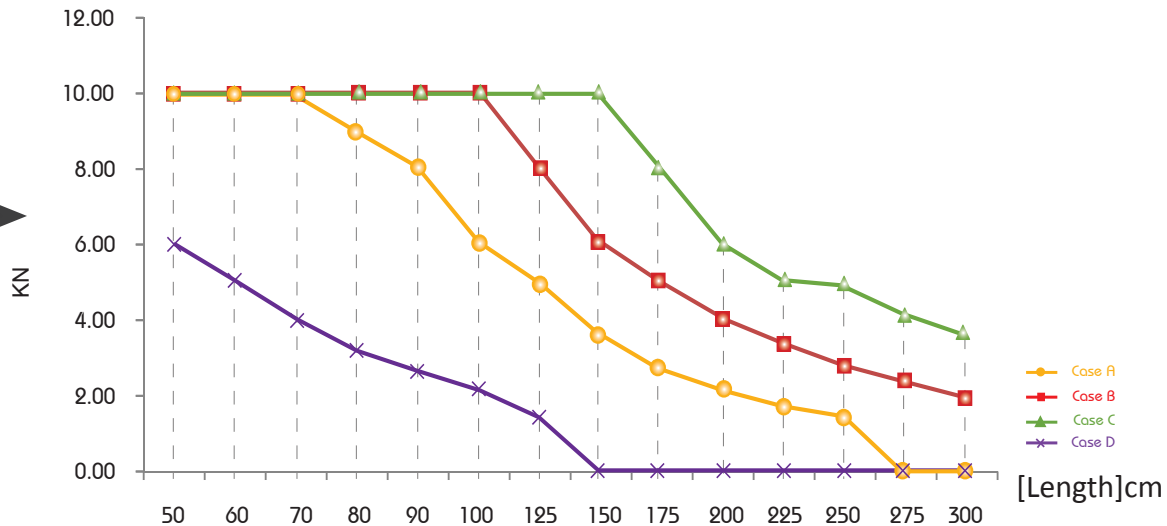

** Given loads are always "allowable characteristic live load"

Load table for single beam with uniform (characteristic) Live-Load

This associated data are considered for perforated and non-perforated c-channel types according to DIN 18.800

Thickness : 1.5 mm
 Standard Length : 3.00 m
 Finishes : Pre-Galvanized,
 Hot-Dip Galvanized.

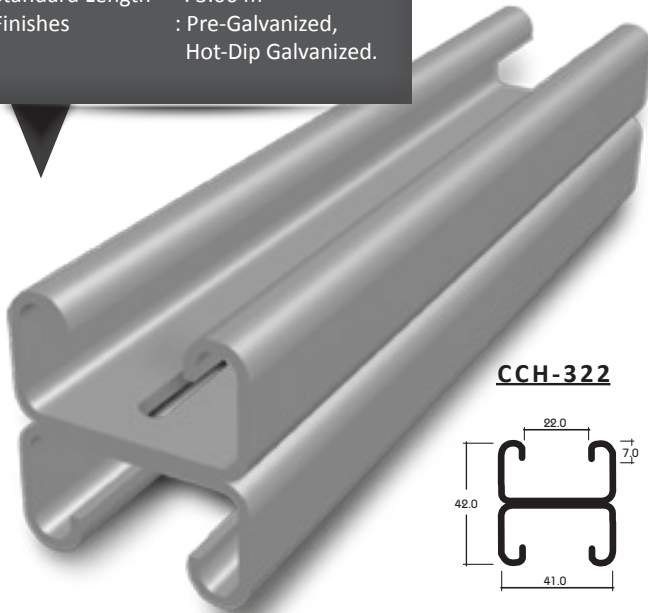

C-Channel:	41x21x2.0 b2b	
Area of Shear (A_s)	0.71	cm ²
Moment of Inertia (I_y)	4.60	cm ⁴
Moment of Inertia (I_z)	8.51	cm ⁴
min. Section Modulus (S_y)	2.19	cm ³
Warping Constant (I_w)	19.76	cm ⁶
Torsional Constant (I_T)	0.06	cm ⁴
Plastic Moment cap. ($M_{pl,y}$)	0.66	kNm
Self weight (G)	2.54	kg/m

Chosen Material:	40 B = S 235 JRG2	
Allowable Bending Stress	21,82	kN/cm ²
Allowable Shear Stress	12,60	kN/cm ²
Modulus of Elasticity	21.000	kN/cm ²

Beam Load Data

Span (L) [cm]	Allowable Load*		Deflection U [mm]	[L / X]	Uniform Load* @	
	q [kN/m]	F [kN]			L / 360 q [kN/m]	L / 180 q [kN/m]
50	8.20	2.10	0.86	580	8.20	8.20
60	5.70	1.70	1.24	480	5.70	5.70
70	4.20	1.50	1.70	410	4.20	4.20
80	3.20	1.30	2.21	360	3.20	3.20
90	2.50	1.10	2.76	330	2.30	2.50
100	2.00	1.00	3.37	300	1.60	2.00
125	1.30	0.80	5.35	230	0.80	1.30
150	0.90	0.70	7.68	200	0.50	0.90
175	0.67	0.60	10.59	170	0.30	0.60
200	0.51	0.50	13.75	150	0.20	0.40
225	0.40	0.50	17.27	130	x	0.30
250	0.33	0.40	21.72	120	x	0.20
275	0.27	0.37	26.02	110	x	x
300	0.23	0.35	31.39	100	x	x

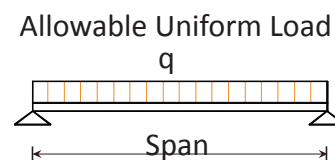
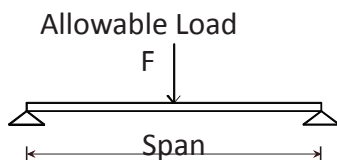

* Given loads are always "allowable characteristic live load"

BEAM LOADING GRAPH CCH-322

Allowable Loads

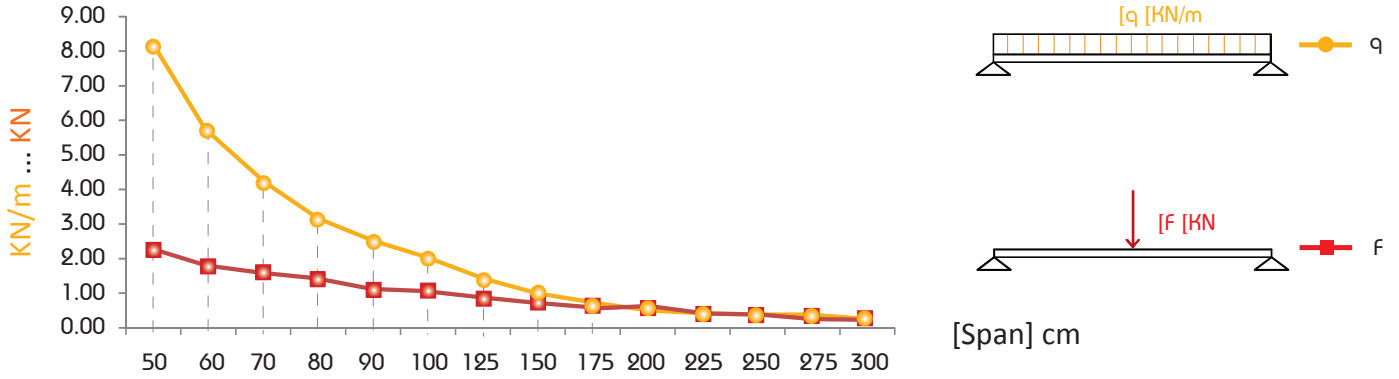

Deflection @ Allowable Uniform Load

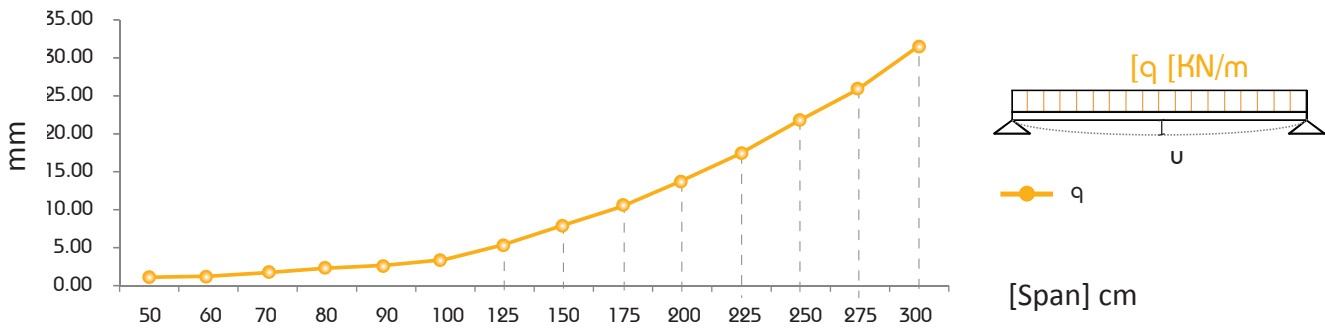

Uniform Load @ Allowable Deflection

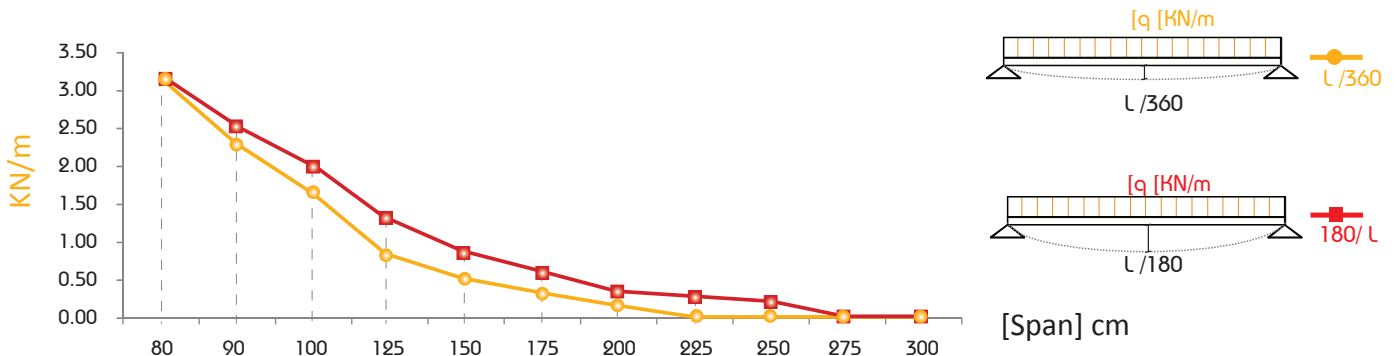

Load table for single beam with uniform (characteristic) Live-Load

This associated data are considered for perforated and non-perforated c-channel types according to DIN 18.800

C-Channel:	41 x 21 x 2.0 b2b	
Cross Section Area (A)	3.67	cm ²
Moment of Inertia (I _y)	21.11	cm ⁴
Moment of Inertia (I _z)	11.37	cm ⁴
Self weight (G)	2.88	kg/m

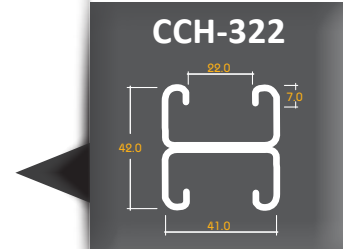

Span (L) [cm]	Allowable Central Load** [kN]			
	Case A	Case B	Case C	Case D
50	24.00	24.00	24.00	24.00
60	24.00	24.00	24.00	24.00
70	24.00	24.00	24.00	24.00
80	24.00	24.00	24.00	24.00
90	24.00	24.00	24.00	23.00
100	24.00	24.00	24.00	20.00
125	24.00	24.00	24.00	14.00
150	24.00	24.00	24.00	10.00
175	24.00	24.00	24.00	8.00
200	20.00	24.00	24.00	6.00
225	17.00	24.00	24.00	5.00
250	14.00	24.00	24.00	4.40
275	12.00	21.00	24.00	3.70
300	10.00	19.00	24.00	x

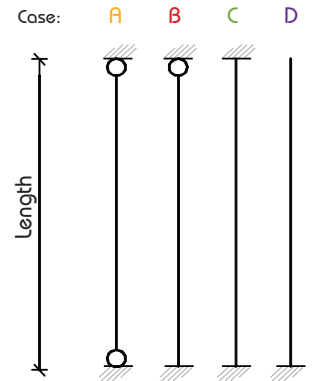

Column Load Data

Allowable Central Load**

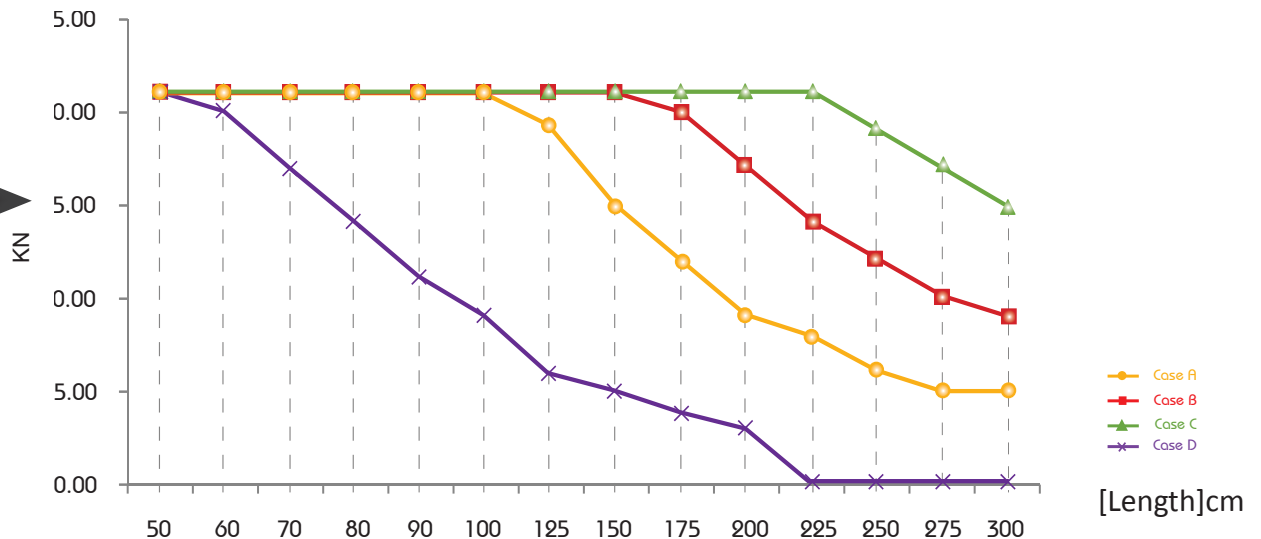

** Given loads are always "allowable characteristic live load"

CCH-340/341

Load table for single beam with uniform (characteristic) Live-Load

This associated data are considered for perforated and non-perforated c-channel types according to DIN 18.800

Thickness : 2.0 mm
 Standard Length : 3.00 m
 Finishes : Pre-Galvanized,
 Hot-Dip Galvanized.

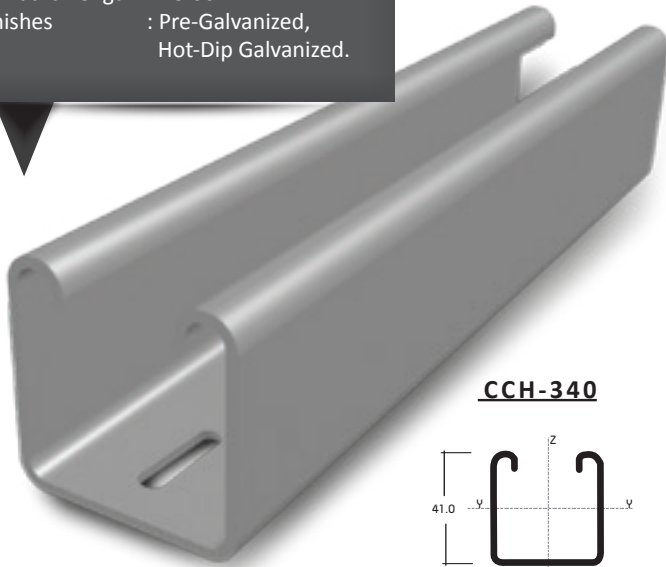

C-Channel:	41x41x2.0	
Area of Shear (A_z)	1.34	cm ²
Moment of Inertia (I_y)	4.59	cm ⁴
Moment of Inertia (I_z)	6.99	cm ⁴
min. Section Modulus (S_y)	2.18	cm ³
Warping Constant (I_w)	138.49	cm ⁶
Torsional Constant (I_T)	0.03	cm ⁴
Plastic Moment cap. ($M_{pl,y}$)	0.64	kNm
Self weight (G)	1.83	kg/m

Chosen Material:	40 B = S 235 JRG2	
Allowable Bending Stress	21,82	kN/cm ²
Allowable Shear Stress	12,60	kN/cm ²
Modulus of Elasticity	21.000	kN/cm ²

Beam Load Data

Span (L)	Allowable Load*		Deflection		Uniform Load* @	
					L / 360	L / 180
[cm]	q [kN/m]	F [kN]	U [mm]	[L/X]	q [kN/m]	q [kN/m]
50	8.10	2.00	0.85	580	8.10	8.10
60	5.60	1.70	1.23	490	5.60	5.60
70	4.10	1.40	1.66	420	4.10	4.10
80	3.20	1.30	2.21	360	3.20	3.20
90	2.50	1.10	2.77	320	2.30	2.50
100	2.00	1.00	3.38	300	1.60	2.00
125	1.30	0.80	5.36	230	0.80	1.30
150	0.90	0.70	7.69	190	0.50	0.90
175	0.66	0.60	10.45	170	0.30	0.60
200	0.51	0.50	13.78	150	0.20	0.40
225	0.40	0.50	17.31	130	x	0.30
250	0.32	0.40	21.11	120	x	0.20
275	0.27	0.37	26.07	110	x	x
300	0.23	0.35	31.46	100	x	x

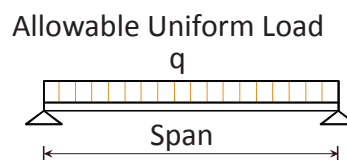
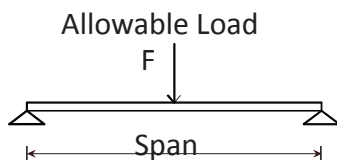

* Given loads are always "allowable characteristic live load"

BEAM LOADING GRAPH CCH-340/341

Allowable Loads

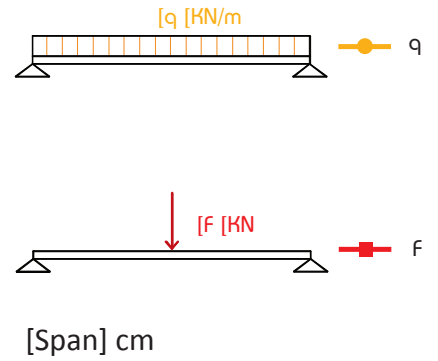
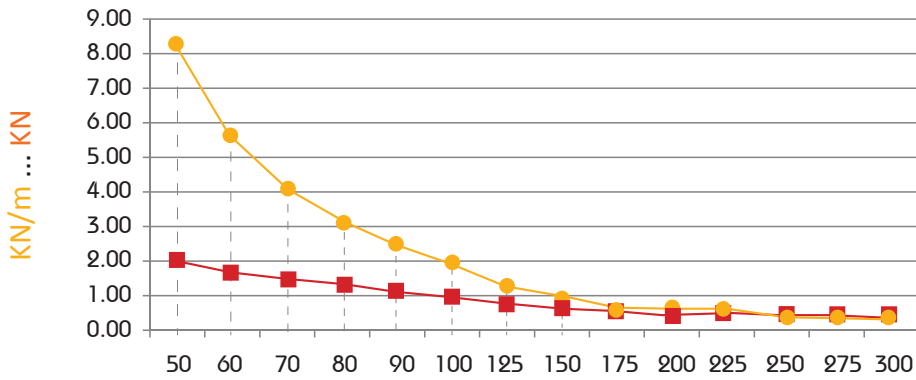

Deflection @ Allowable Uniform Load

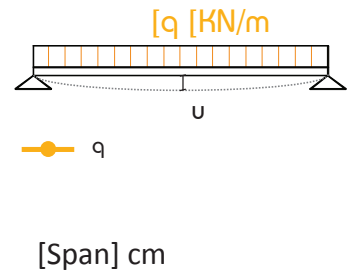
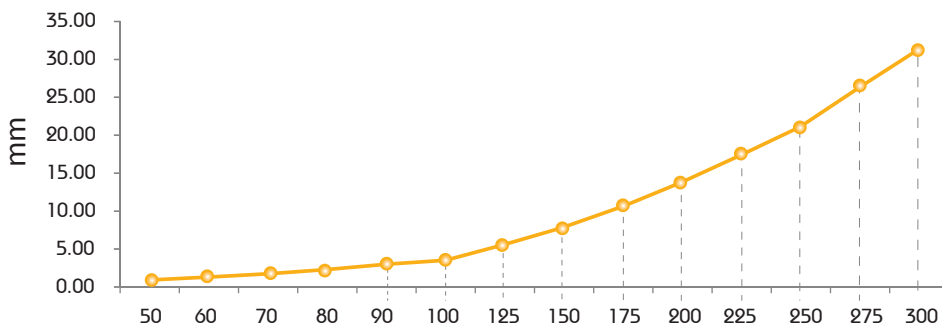

Uniform Load @ Allowable Deflection

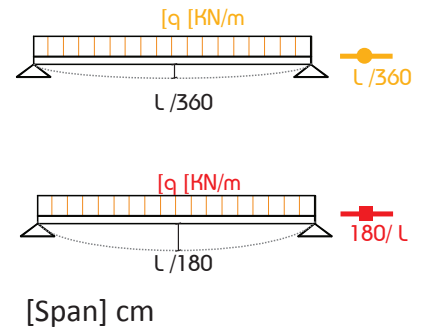
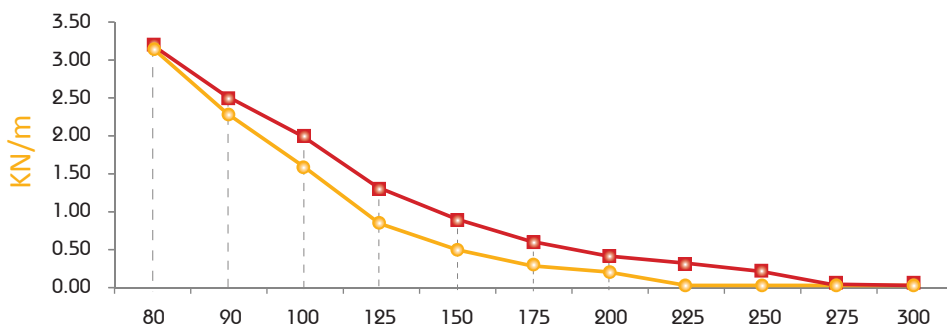

Load table for single beam with uniform (characteristic) Live-Load

This associated data are considered for perforated and non-perforated c-channel types according to DIN 18.800

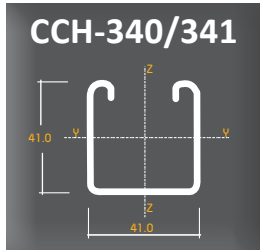

C-Channel:	41 x 41 x 2.0	
Cross Section Area (A)	2.33	cm ²
Moment of Inertia (I _y)	4.59	cm ⁴
Moment of Inertia (I _z)	6.99	cm ⁴
Self weight (G)	1.83	kg/m

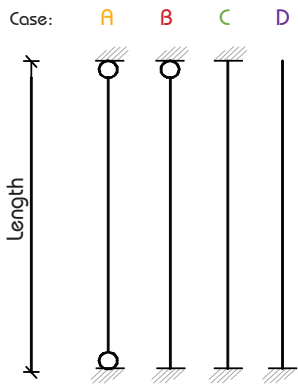

Span (L) [cm]	Allowable Central Load** [KN]			
	Case A	Case B	Case C	Case D
50	15.00	15.00	15.00	15.00
60	15.00	15.00	15.00	15.00
70	15.00	15.00	15.00	15.00
80	15.00	15.00	15.00	12.00
90	15.00	15.00	15.00	10.00
100	15.00	15.00	15.00	9.00
125	15.00	15.00	15.00	6.00
150	13.00	15.00	15.00	4.70
175	11.00	15.00	15.00	3.60
200	9.00	15.00	15.00	2.80
225	7.00	13.00	15.00	2.20
250	6.00	11.00	15.00	x
275	5.00	9.00	15.00	x
300	4.70	8.00	13.00	x

Column Load Data

Allowable Central Load**

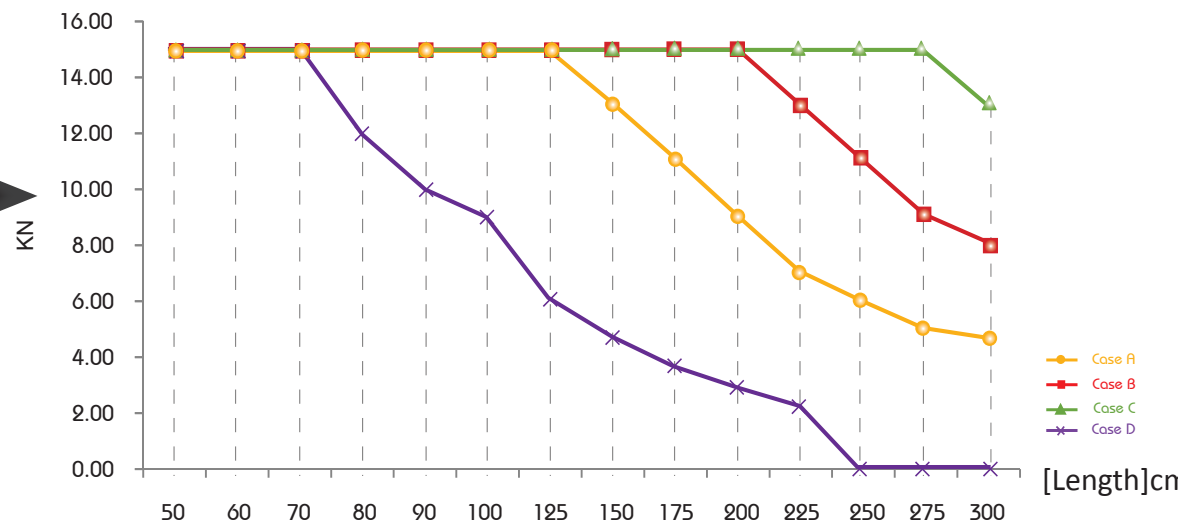

** Given loads are always "allowable characteristic live load"

Load table for single beam with uniform (characteristic) Live-Load

This associated data are considered for perforated and non-perforated c-channel types according to DIN 18.800

Thickness : 2.0 mm
 Standard Length : 3.00 m
 Finishes : Pre-Galvanized,
 Hot-Dip Galvanized.

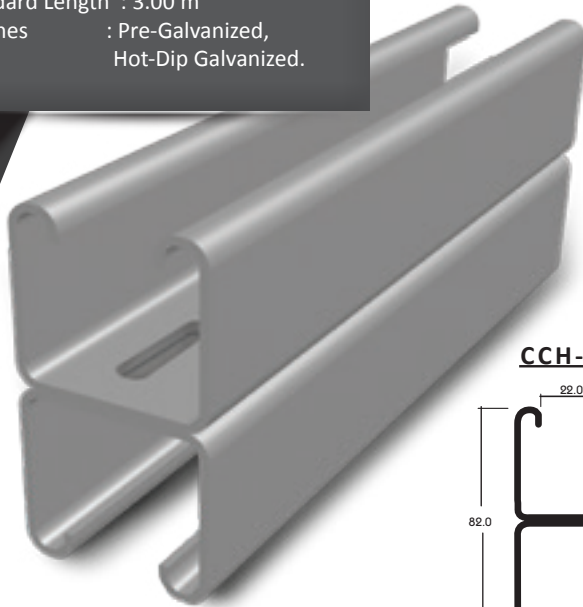

C-Channel:	41x41x2.0 b2b	
Area of Shear (A_z)	1.88	cm ²
Moment of Inertia (I_y)	26.81	cm ⁴
Moment of Inertia (I_z)	14.04	cm ⁴
min. Section Modulus (S_y)	6.62	cm ³
Warping Constant (I_w)	113.65	cm ⁶
Torsional Constant (I_t)	0.08	cm ⁴
Plastic Moment cap. (M_{ply})	1.98	kNm
Self weight (G)	3.76	kg/m

Chosen Material:	40 B = S 235 JRG2	
Allowable Bending Stress	21,82	kN/cm ²
Allowable Shear Stress	12,60	kN/cm ²
Modulus of Elasticity	21.000	kN/cm ²

Beam Load Data

Span (L) [cm]	Allowable Load*		Deflection U [mm]	[L / X]	Uniform Load* @	
	q [kN/m]	F [kN]			L / 360 q [kN/m]	L / 180 q [kN/m]
50	24.70	6.20	0.45	1.120	24.70	24.70
60	17.10	5.10	0.64	940	17.10	17.10
70	12.60	4.40	0.87	800	12.60	12.60
80	9.60	3.80	1.14	700	9.60	9.60
90	7.60	3.40	1.44	620	7.60	7.60
100	6.20	3.10	1.79	560	6.20	6.20
125	3.90	2.40	2.75	450	3.90	3.90
150	2.70	2.00	3.9	380	2.70	2.70
175	2.00	1.80	5.42	320	1.80	2.00
200	1.50	1.50	6.4	290	1.20	1.50
225	1.10	1.20	8.15	280	0.80	1.10
250	0.90	1.10	10.16	250	0.60	0.90
275	0.66	0.90	10.91	250	0.50	0.70
300	0.52	0.80	12.18	250	0.40	0.50

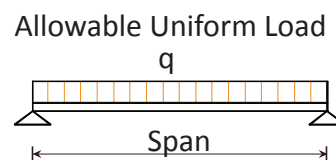
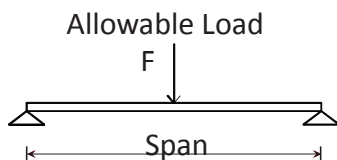

* Given loads are always "allowable characteristic live load"

BEAM LOADING GRAPH CCH-342

Allowable Loads

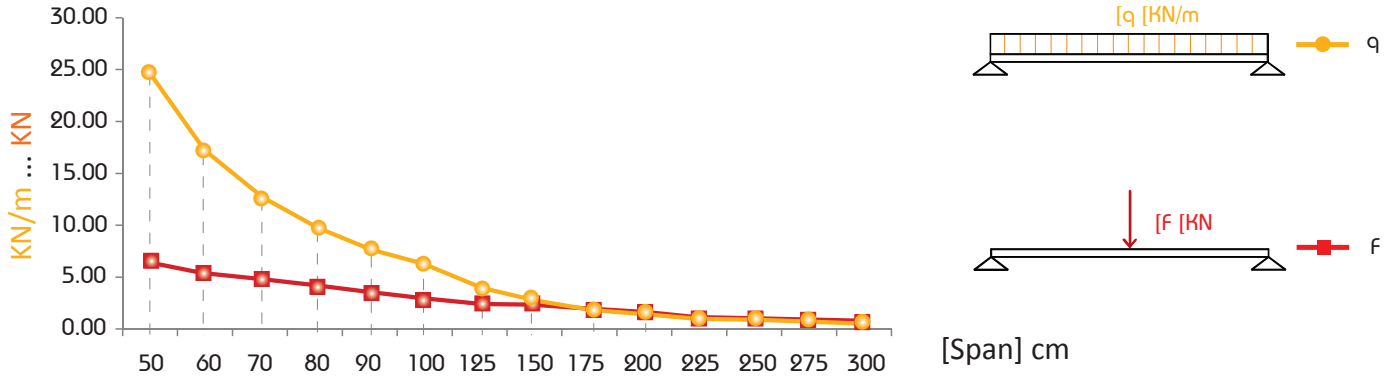

Deflection @ Allowable Uniform Load

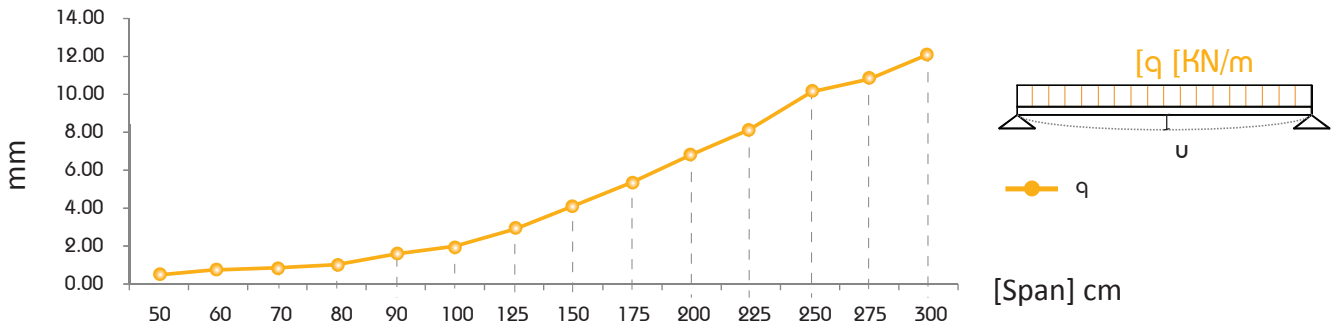

Uniform Load @ Allowable Deflection

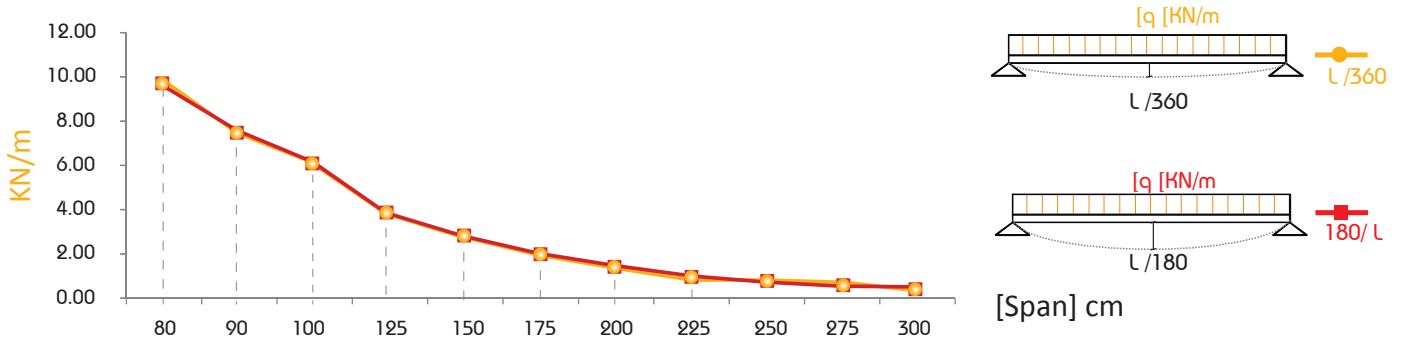

Load table for single beam with uniform (characteristic) Live-Load

This associated data are considered for perforated and non-perforated c-channel types according to DIN 18.800

C-Channel:	41 x 41 x 2.0 b2b	
Cross Section Area (A)	4.79	cm ²
Moment of Inertia (I _y)	26.81	cm ⁴
Moment of Inertia (I _z)	14.04	cm ⁴
Self weight (G)	3.76	kg/m

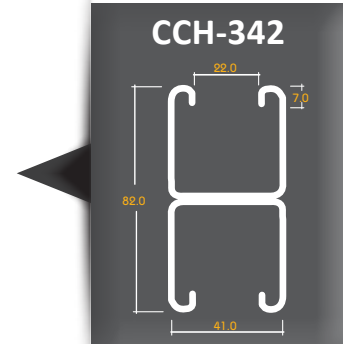

Span (L) [cm]	Allowable Central Load** [KN]			
	Case A	Case B	Case C	Case D
50	31.00	31.00	31.00	31.00
60	31.00	31.00	31.00	31.00
70	31.00	31.00	31.00	31.00
80	31.00	31.00	31.00	31.00
90	31.00	31.00	31.00	29.00
100	31.00	31.00	31.00	25.00
125	31.00	31.00	31.00	18.00
150	31.00	31.00	31.00	13.00
175	30.00	31.00	31.00	10.00
200	25.00	31.00	31.00	8.00
225	21.00	31.00	31.00	6.00
250	18.00	30.00	31.00	5.00
275	15.00	26.00	31.00	4.60
300	13.00	23.00	31.00	x

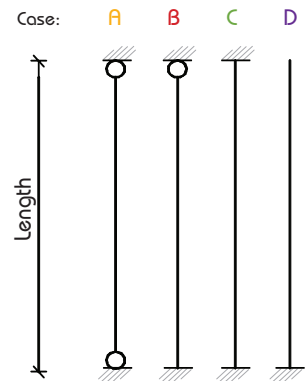

Column Load Data

Allowable Central Load**

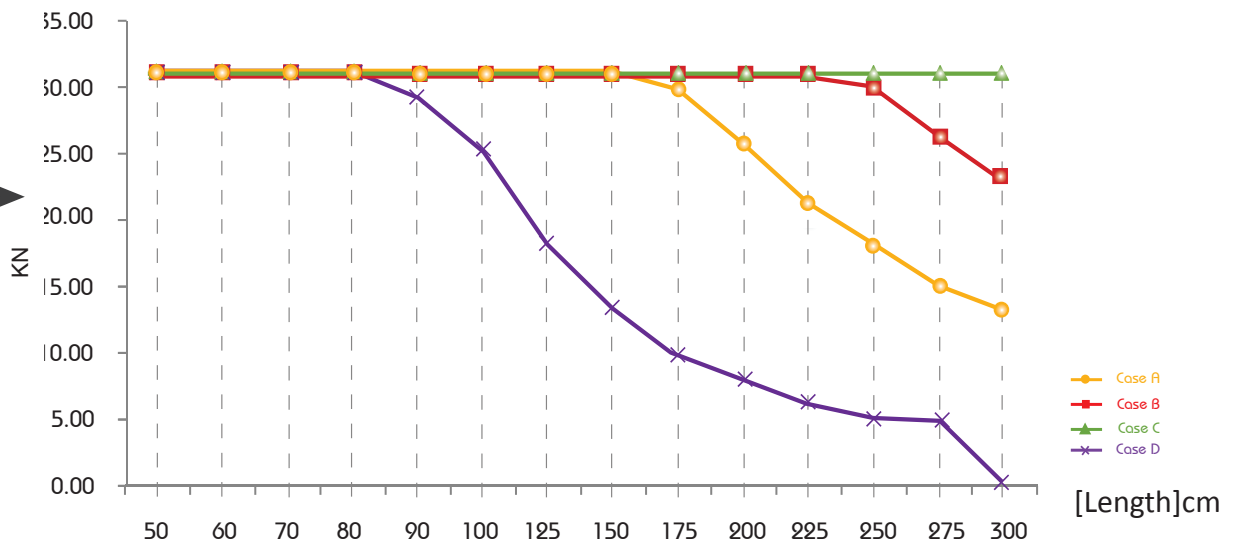

** Given loads are always "allowable characteristic live load"

Load table for single beam with uniform (characteristic) Live-Load

This associated data are considered for perforated and non-perforated c-channel types according to DIN 18.800

Thickness : 2.0 mm
 Standard Length : 3.00 m
 Finishes : Pre-Galvanized, Hot-Dip Galvanized.

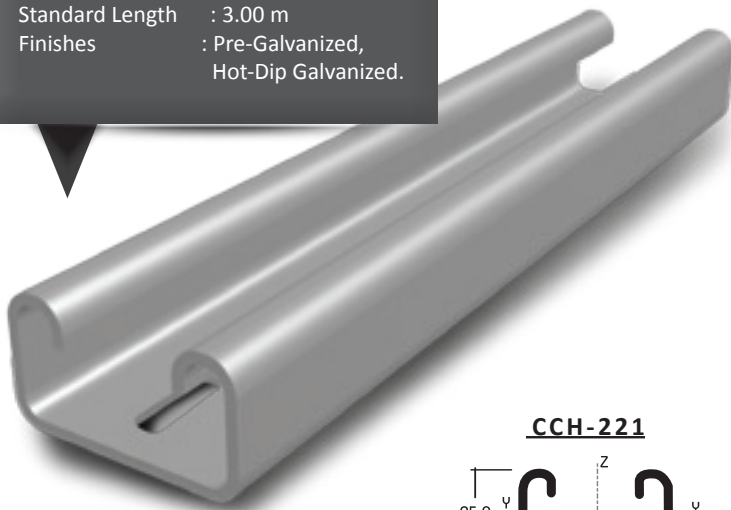

C-Channel:	50 x 25 x 2.0	
Area of Shear (A_z)	0.68	cm ²
Moment of Inertia (I_y)	1.51	cm ⁴
Moment of Inertia (I_z)	7.87	cm ⁴
min. Section Modulus (S_y)	1.05	cm ³
Warping Constant (I_w)	50.65	cm ⁶
Torsional Constant (I_t)	0.03	cm ⁴
Plastic Moment cap. ($M_{pl,y}$)	0.34	kNm
Self weight (G)	1.55	kg/m

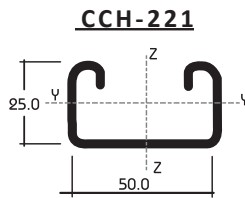

Chosen Material:	S 235 JRG2	
Allowable Bending Stress	21,82	kN/cm ²
Allowable Shear Stress	12,60	kN/cm ²
Modulus of Elasticity	21.000	kN/cm ²

Beam Load Data

Span (L) [cm]	Allowable Load*		Deflection		Uniform Load* @	
					L / 360	L / 180
	q [kN/m]	F [kN]	U [mm]	[L/X]	q [kN/m]	q [kN/m]
30	10.90	1.60	0.40	750	10.90	10.90
40	6.10	1.20	0.71	570	6.10	6.10
50	3.90	1.00	1.11	450	3.90	3.90
60	2.70	0.80	1.59	380	2.50	2.70
70	2.00	0.70	2.19	320	1.58	1.99
80	1.50	0.60	2.80	290	1.06	1.53
90	1.20	0.54	3.60	250	0.74	1.21
100	1.00	0.50	4.59	220	0.54	0.98
125	0.63	0.39	7.12	180	0.28	0.55
150	0.43	0.32	10.19	150	0.16	0.32
175	0.32	0.28	14.21	120	x	0.20
200	0.24	0.24	18.46	110	x	x
225	0.19	0.21	23.79	90	x	x
250	x	x	x	x	x	x
275	x	x	x	x	x	x
300	x	x	x	x	x	x

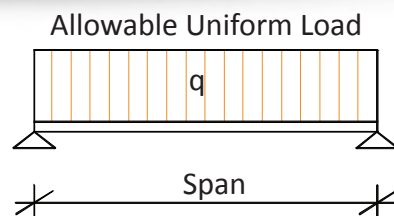
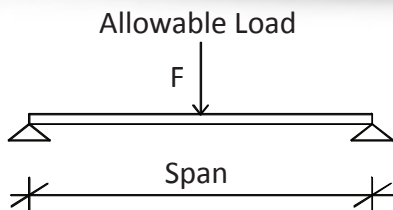

* Given loads are always "allowable characteristic live load"

BEAM LOADING GRAPH CCH-360/361

Allowable Loads

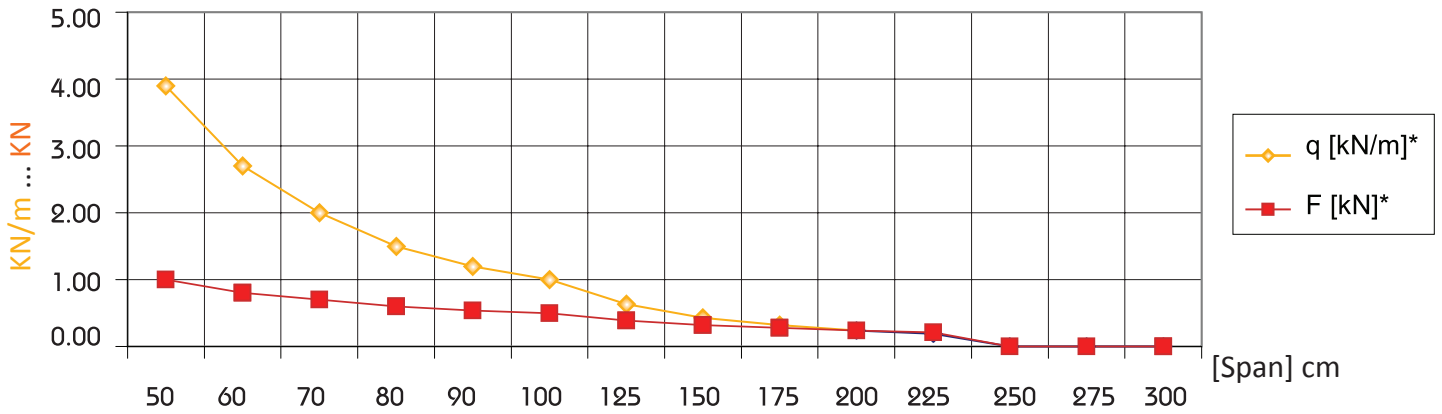

Deflection @ Allowable Uniform Load

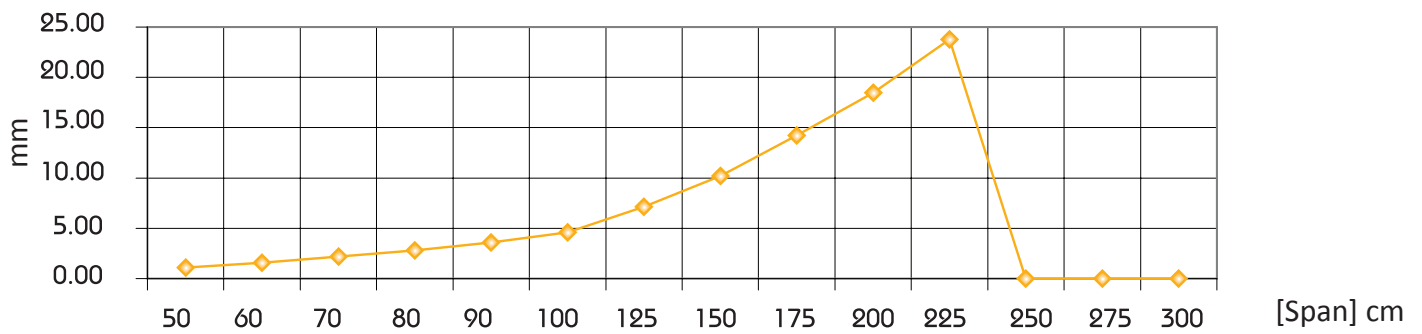

Uniform Load @ Allowable Deflection

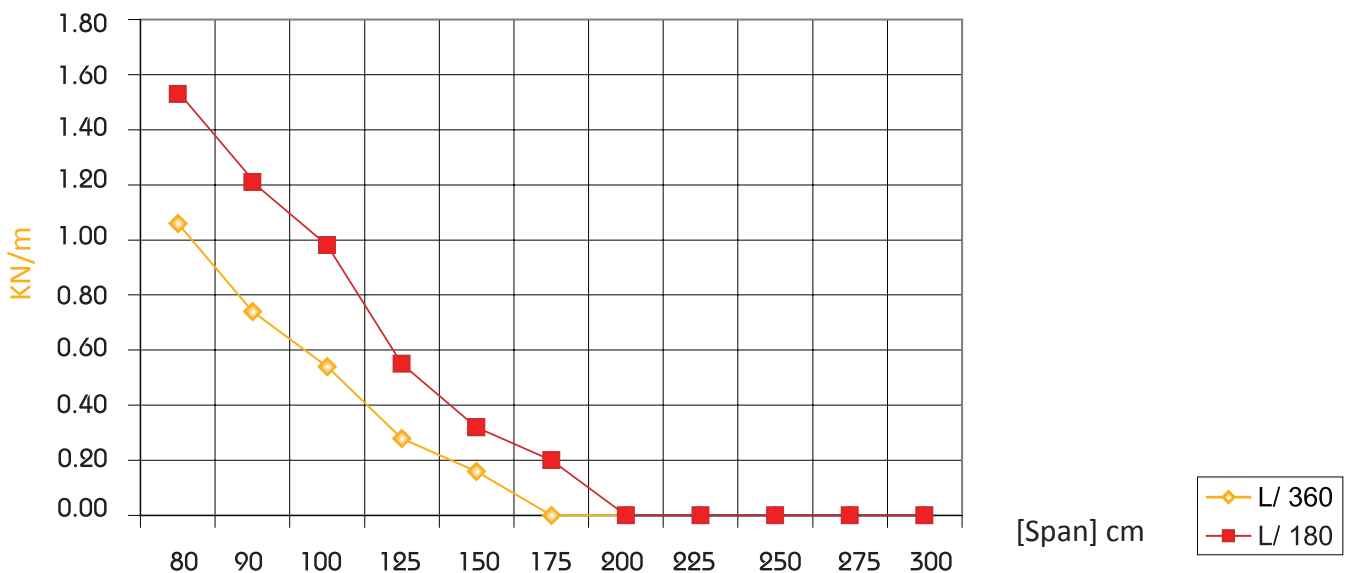

Load table for single beam with uniform (characteristic) Live-Load

This associated data are considered for perforated and non-perforated c-channel types according to DIN 18.800

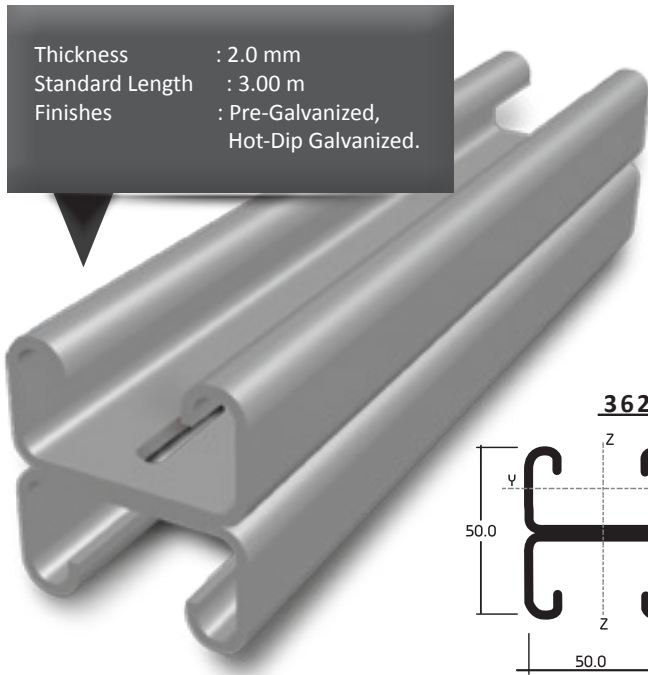

C-Channel:	50 x 25 x 2.0 b2b	
Area of Shear (A_z)	1.39	cm ²
Moment of Inertia (I_y)	7.33	cm ⁴
Moment of Inertia (I_z)	15.75	cm ⁴
min. Section Modulus (S_y)	2.93	cm ³
Warping Constant (I_w)	43.54	cm ⁶
Torsional Constant (I_t)	0.06	cm ⁴
Plastic Moment cap. ($M_{pl,y}$)	0.88	kNm
Self weight (G)	3.00	kg/m

Chosen Material:	S 235 JRG2	
Allowable Bending Stress	21,82	kN/cm ²
Allowable Shear Stress	12,60	kN/cm ²
Modulus of Elasticity	21.000	kN/cm ²

Beam Load Data

Span (L) [cm]	Allowable Load*		Deflection U [mm]	[L/X]	Uniform Load* @	
	q [kN/m]	F [kN]			L / 360 q [kN/m]	L / 180 q [kN/m]
50	10,90	2,70	0,64	790	10,90	10,90
60	7,60	2,30	0,92	650	7,60	7,60
70	5,60	2,00	1,26	560	5,60	5,60
80	4,30	1,70	1,65	480	4,30	4,30
90	3,40	1,50	2,09	430	3,40	3,40
100	2,70	1,40	2,54	390	2,60	2,70
125	1,70	1,10	3,93	320	1,30	1,70
150	1,20	0,90	5,79	260	0,80	1,20
175	0,90	0,79	8,12	220	0,49	0,89
200	0,68	0,68	10,57	190	0,33	0,66
225	0,54	0,61	13,59	170	0,23	0,46
250	0,44	0,55	17,08	150	0,17	0,34
275	0,36	0,50	20,75	130	x	0,25
300	0,30	0,45	24,87	120	x	0,19

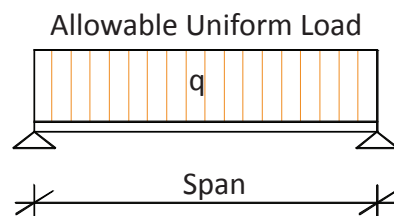
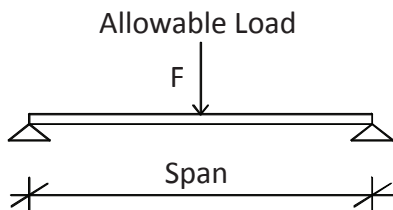

* Given loads are always "allowable characteristic live load"

BEAM LOADING GRAPH CCH-362

Allowable Loads

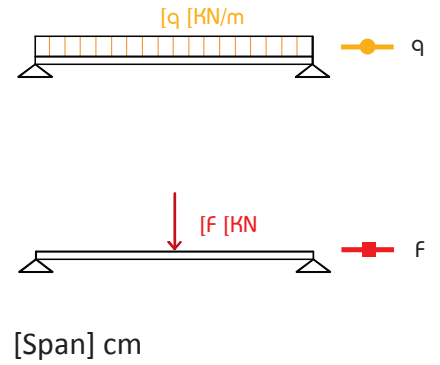
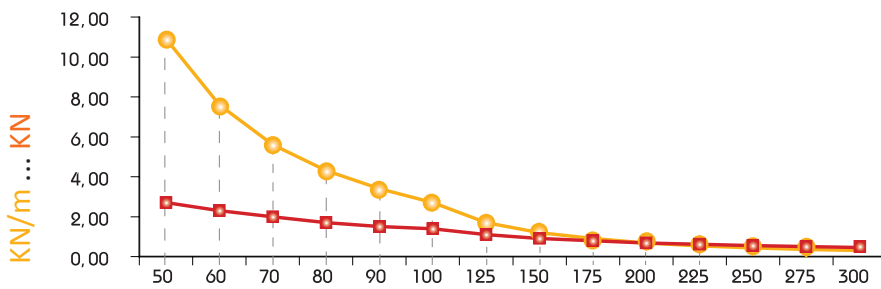

Deflection @ Allowable Uniform Load

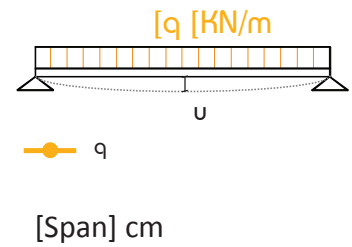
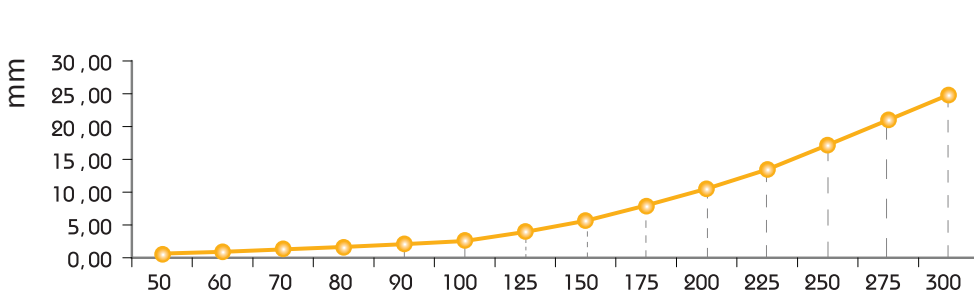

Uniform Load @ Allowable Deflection

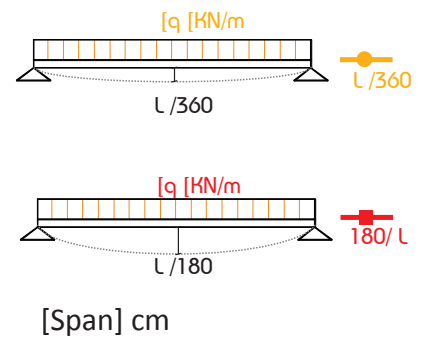
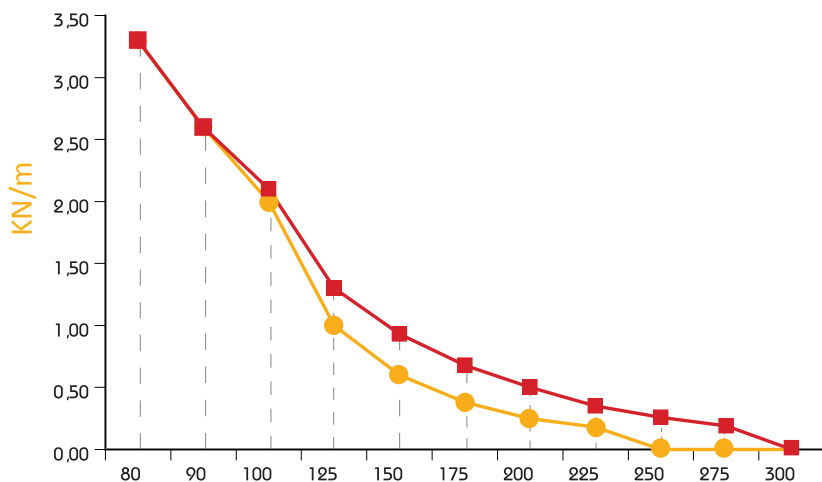

CCH-420/421

Load table for single beam with uniform (characteristic) Live-Load

This associated data are considered for perforated and non-perforated c-channel types according to DIN 18.800

Thickness : 2.5 mm
 Standard Length : 3.00 m
 Finishes : Pre-Galvanized,
 Hot-Dip Galvanized.

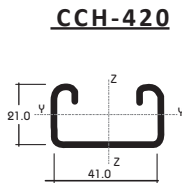

C-Channel:	41x21x2.5	
Area of Shear (A_z)	0.67	cm ²
Moment of Inertia (I_y)	1.03	cm ⁴
Moment of Inertia (I_z)	5.07	cm ⁴
min. Section Modulus (S_y)	0.89	cm ³
Warping Constant (I_w)	24.34	cm ⁶
Torsional Constant (I_t)	0.06	cm ⁴
Plastic Moment cap. ($M_{pl,y}$)	0.29	kNm
Self weight (G)	1.56	kg/m

Chosen Material:	40 B = S 235 JRG2	
Allowable Bending Stress	21,82	kN/cm ²
Allowable Shear Stress	12,60	kN/cm ²
Modulus of Elasticity	21.000	kN/cm ²

Beam Load Data

Span (L)	Allowable Load*		Deflection	Uniform Load* @		
				L / 360	L / 180	
[cm]	q [kN/m]	F [kN]	U [mm]	[L/X]	q [kN/m]	q [kN/m]
50	3.30	0.80	1.55	320	3.00	3.30
60	2.30	0.70	2.24	270	1.70	2.30
70	1.70	0.60	3.07	230	1.10	1.70
80	1.30	0.50	4.01	200	0.70	1.30
90	1.00	0.50	4.94	180	0.50	1.00
100	0.80	0.40	6.02	170	0.40	0.70
125	0.53	0.33	9.74	130	0.19	0.38
150	0.37	0.28	14.09	110	x	0.22
175	0.27	0.24	19.05	90	x	x
200	0.21	0.21	25.28	80	x	x
225	0.16	0.28	30.86	70	x	x
250	x	x	x	x	x	x
275	x	x	x	x	x	x
300	x	x	x	x	x	x

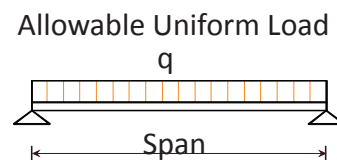
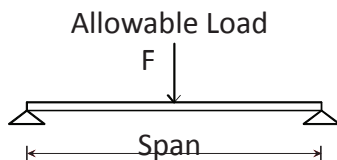

* Given loads are always "allowable characteristic live load"

BEAM LOADING GRAPH CCH-420/421

Allowable Loads

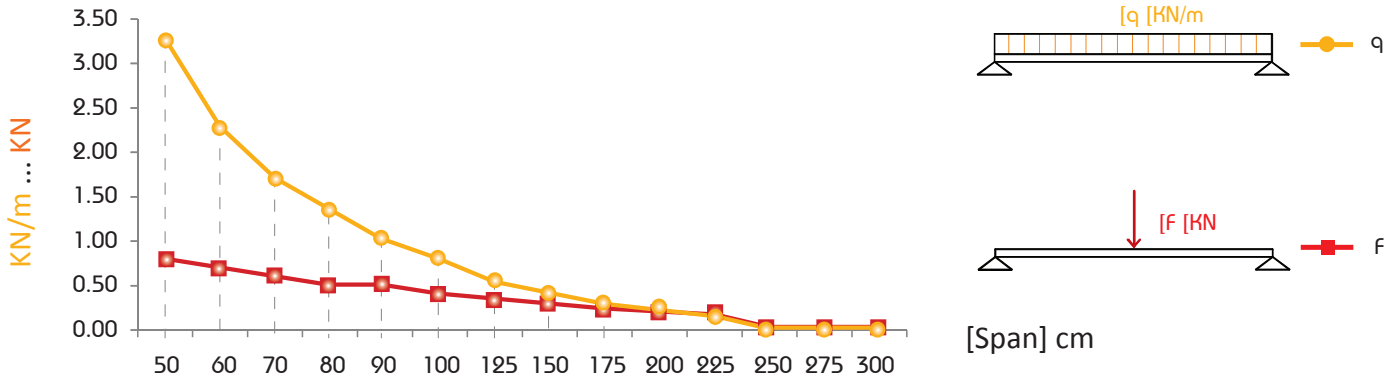

Deflection @ Allowable Uniform Load

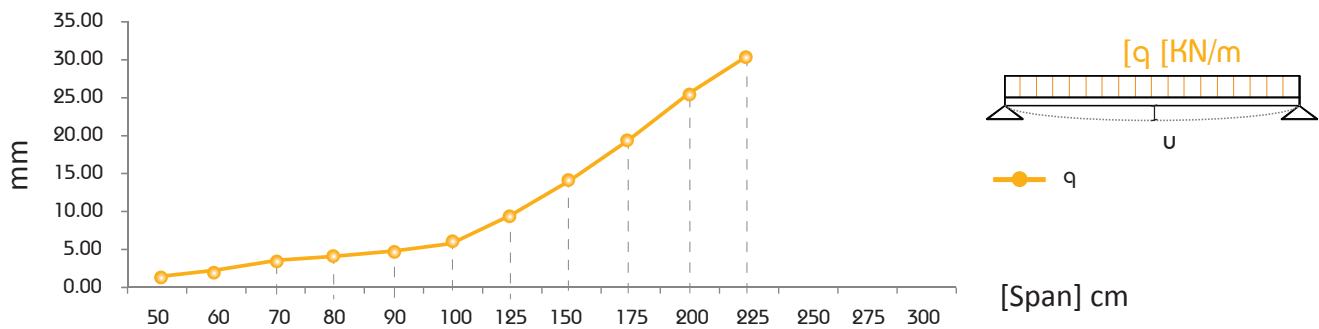

Uniform Load @ Allowable Deflection

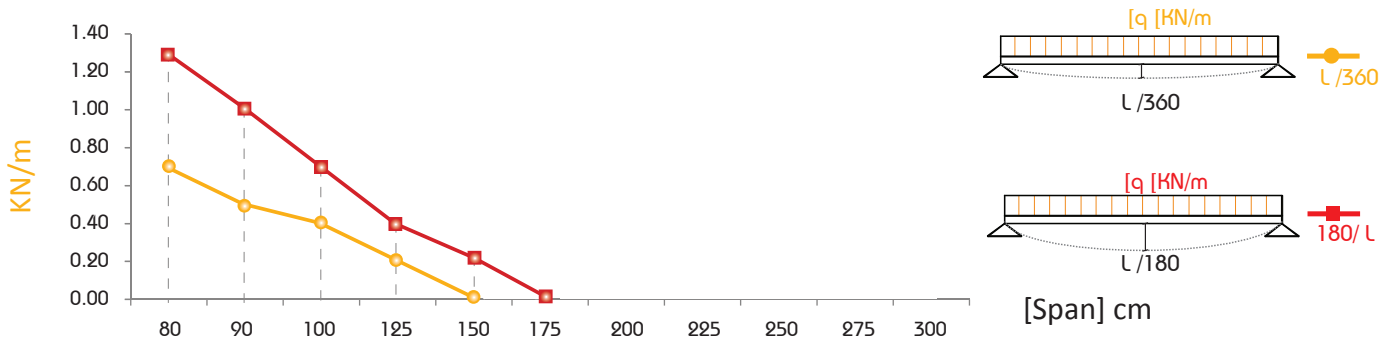

Load table for single beam with uniform (characteristic) Live-Load

This associated data are considered for perforated and non-perforated c-channel types according to DIN 18.800

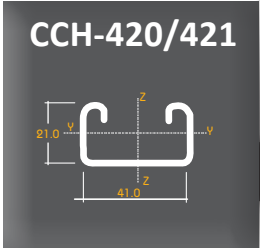

C-Channel:	41 x 21 x 2.5	
Cross Section Area (A)	1.99	cm ²
Moment of Inertia (I _y)	1.03	cm ⁴
Moment of Inertia (I _z)	5.07	cm ⁴
Self weight (G)	1.56	kg/m

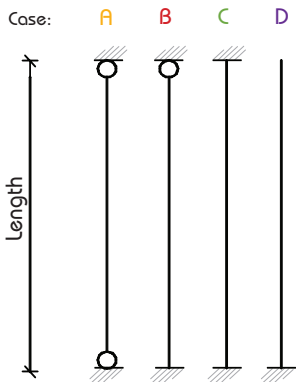

Span (L) [cm]	Allowable Central Load** [kN]			
	Case A	Case B	Case C	Case D
50	13.00	13.00	13.00	8.00
60	13.00	13.00	13.00	6.00
70	13.00	13.00	13.00	4.70
80	11.00	13.00	13.00	3.70
90	9.00	13.00	13.00	3.00
100	8.00	13.00	13.00	2.50
125	5.00	10.00	13.00	x
150	4.20	7.00	12.00	x
175	3.20	5.00	10.00	x
200	2.50	4.70	8.00	x
225	2.00	3.80	6.00	x
250	x	3.20	5.00	x
275	x	2.70	4.90	x
300	x	2.30	4.20	x

Column Load Data

Allowable Central Load**

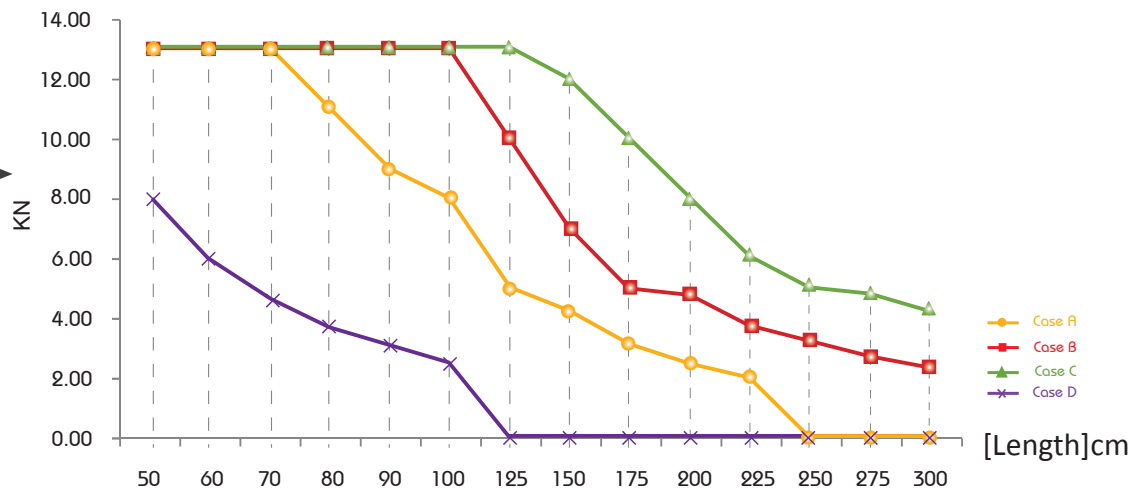

** Given loads are always "allowable characteristic live load"

Load table for single beam with uniform (characteristic) Live-Load

This associated data are considered for perforated and non-perforated c-channel types according to DIN 18.800

Thickness : 2.5 mm
 Standard Length : 3.00 m
 Finishes : Pre-Galvanized,
 Hot-Dip Galvanized.

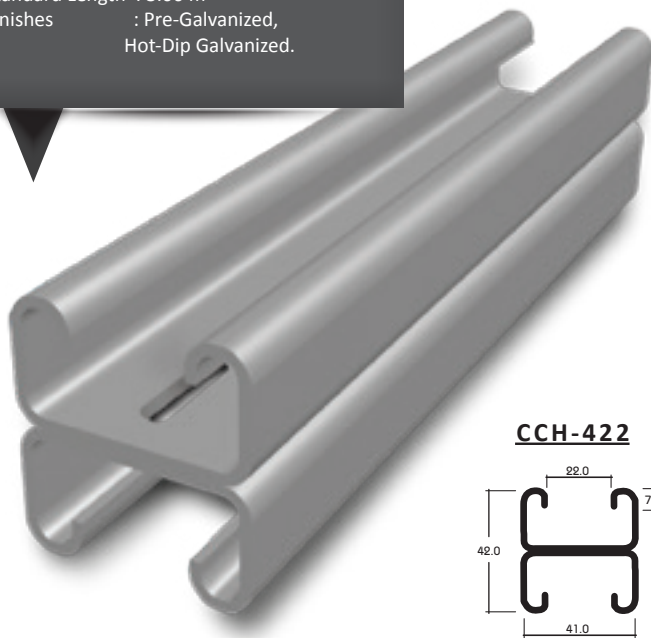

C-Channel:	41x21x2.5 b2b	
Area of Shear (A_z)	0.88	cm ²
Moment of Inertia (I_y)	5.55	cm ⁴
Moment of Inertia (I_z)	10.14	cm ⁴
min. Section Modulus (S_y)	2.65	cm ³
Warping Constant (I_w)	22.30	cm ⁶
Torsional Constant (I_t)	0.12	cm ⁴
Plastic Moment cap. (M_{ply})	0.82	kNm
Self weight (G)	3.13	kg/m

Chosen Material:	40 B = S 235 JRG2	
Allowable Bending Stress	21,82	kN/cm ²
Allowable Shear Stress	12,60	kN/cm ²
Modulus of Elasticity	21.000	kN/cm ²

Beam Load Data

Span (L) [cm]	Allowable Load*		Deflection U [mm]	[L/X]	Uniform Load* @	
	q [kN/m]	F [kN]			L / 360 q [kN/m]	L / 180 q [kN/m]
50	9.90	2.50	0.86	580	9.90	9.90
60	6.90	2.10	1.25	480	6.90	6.90
70	5.00	1.80	1.68	420	5.00	5.00
80	3.90	1.60	2.23	360	3.90	3.90
90	3.00	1.40	2.75	330	2.70	3.00
100	2.50	1.30	3.49	290	2.00	2.50
125	1.60	1.00	5.46	230	1.00	1.60
150	1.10	0.80	7.78	190	0.60	1.10
175	0.80	0.70	10.48	170	0.40	0.70
200	0.62	0.60	13.85	140	0.20	0.50
225	0.49	0.60	17.54	130	0.20	0.30
250	0.39	0.50	21.27	120	x	0.30
275	0.33	0.50	26.36	100	x	0.20
300	0.27	0.40	30.54	100	x	x

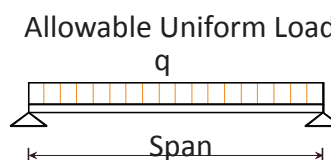
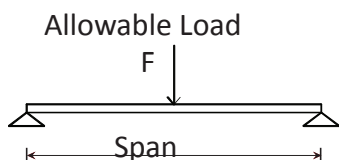

* Given loads are always "allowable characteristic live load"

BEAM LOADING GRAPH CCH-422

Allowable Loads

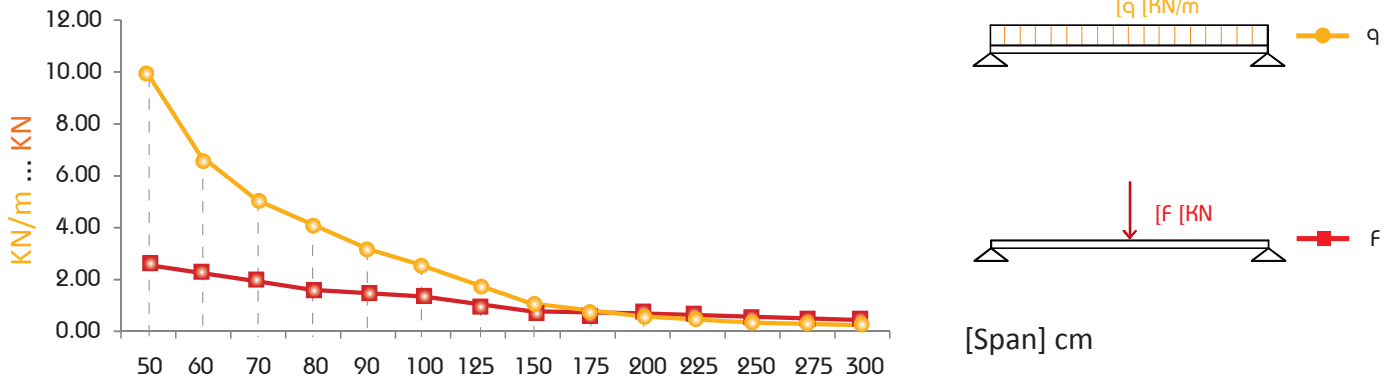

Deflection @ Allowable Uniform Load

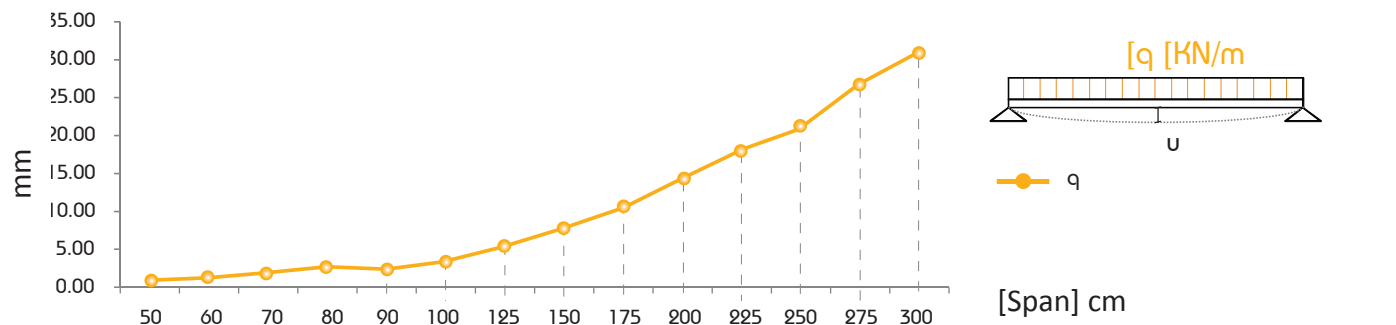

Uniform Load @ Allowable Deflection

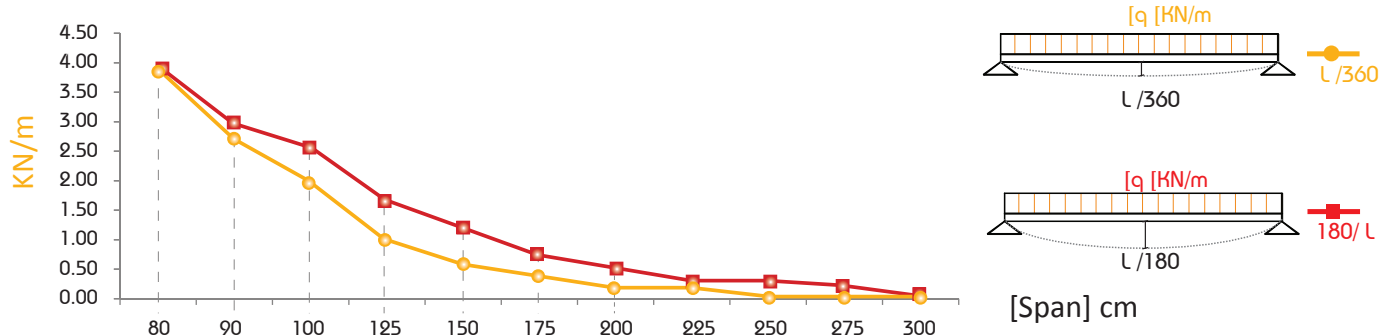

Load table for single beam with uniform (characteristic) Live-Load

This associated data are considered for perforated and non-perforated c-channel types according to DIN 18.800

C-Channel:	41 x 21 x 2.5 b2b	
Cross Section Area (A)	3.99	cm ²
Moment of Inertia (I _y)	5.55	cm ⁴
Moment of Inertia (I _z)	10.14	cm ⁴
Self weight (G)	3.13	kg/m

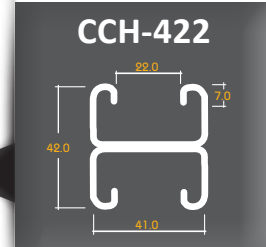

Span (L) [cm]	Allowable Central Load** [kN]			
	Case A	Case B	Case C	Case D
50	26.00	26.00	26.00	26.00
60	26.00	26.00	26.00	25.00
70	26.00	26.00	26.00	20.00
80	26.00	26.00	26.00	17.00
90	26.00	26.00	26.00	14.00
100	26.00	26.00	26.00	11.00
125	24.00	26.00	26.00	8.00
150	18.00	26.00	26.00	5.00
175	14.00	24.00	26.00	4.40
200	11.00	20.00	26.00	3.50
225	9.00	17.00	26.00	x
250	8.00	14.00	24.00	x
275	6.00	12.00	21.00	x
300	5.00	11.00	18.00	x

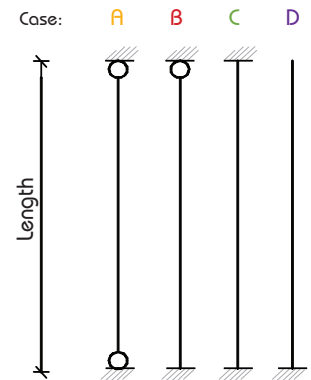

Column Load Data

Allowable Central ** Load

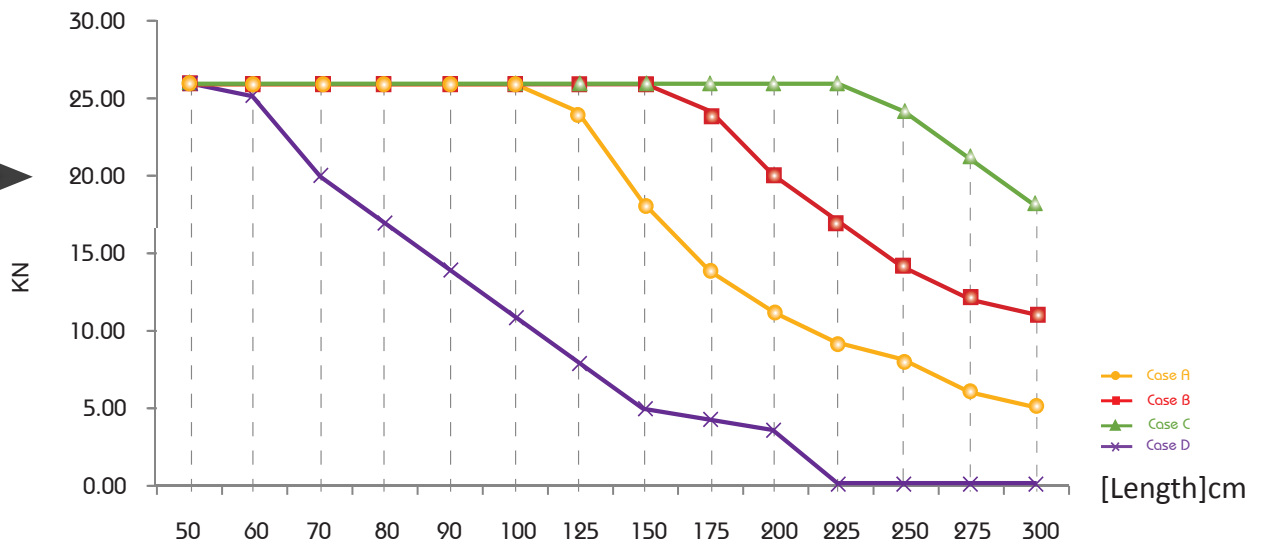

** Given loads are always "allowable characteristic live load"

CCH-440/441

Load table for single beam with uniform (characteristic) Live-Load

This associated data are considered for perforated and non-perforated c-channel types according to DIN 18.800

Thickness : 2.5 mm
 Standard Length : 3.00 m
 Finishes : Pre-Galvanized,
 Hot-Dip Galvanized.

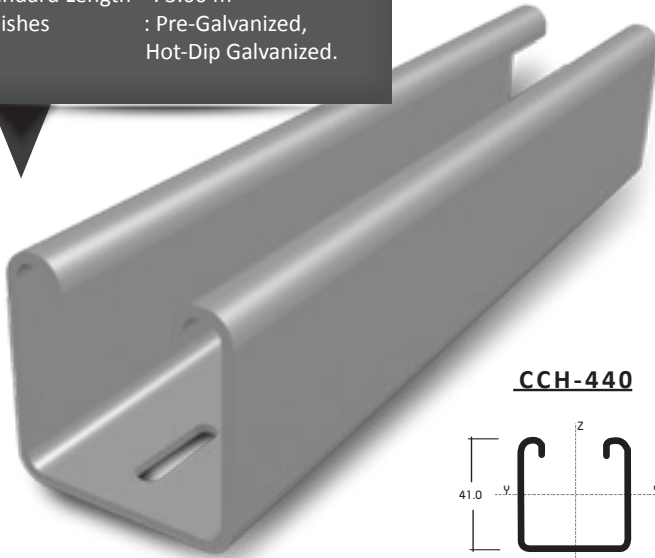

C-Channel:	41x41x2.5	
Area of Shear (A_z)	1.67	cm ²
Moment of Inertia (I_y)	5.87	cm ⁴
Moment of Inertia (I_z)	8.76	cm ⁴
min. Section Modulus (S_y)	2.72	cm ³
Warping Constant (I_w)	171.52	cm ⁶
Torsional Constant (I_t)	0.07	cm ⁴
Plastic Moment cap. ($M_{pl,y}$)	0.82	kNm
Self weight (G)	2.32	kg/m

Chosen Material:	40 B = S 235 JRG2	
Allowable Bending Stress	21,82	kN/cm ²
Allowable Shear Stress	12,60	kN/cm ²
Modulus of Elasticity	21.000	kN/cm ²

Beam Load Data

Span (L)	Allowable Load*		Deflection		@ *Uniform Load	
					L / 360	L / 180
[cm]	[q [kN/m]	[F [kN]	[U [mm]	[L/X]	[q [kN/m]	[q [kN/m]
50	10.10	2.50	0.83	600	10.10	10.10
60	7.00	2.10	1.20	500	7.00	7.00
70	5.20	1.80	1.65	420	5.20	5.20
80	4.00	1.60	2.16	370	4.00	4.00
90	3.10	1.40	2.69	340	2.90	3.10
100	2.50	1.30	3.30	300	2.10	2.50
125	1.60	1.00	5.16	240	1.10	1.60
150	1.10	0.80	7.35	200	0.60	1.10
175	0.80	0.70	9.91	180	0.40	0.80
200	0.63	0.60	13.31	150	0.30	0.50
225	0.50	0.60	16.92	130	0.20	0.40
250	0.41	0.50	21.15	120	x	0.30
275	0.33	0.50	24.92	110	x	0.20
300	0.28	0.40	29.95	100	x	x

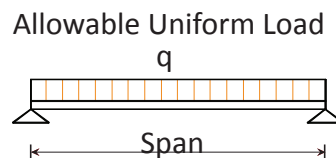
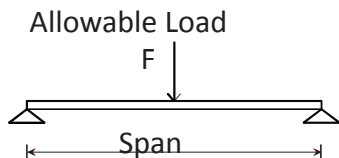

* Given loads are always "allowable characteristic live load"

BEAM LOADING GRAPH CCH-440/441

Allowable Loads

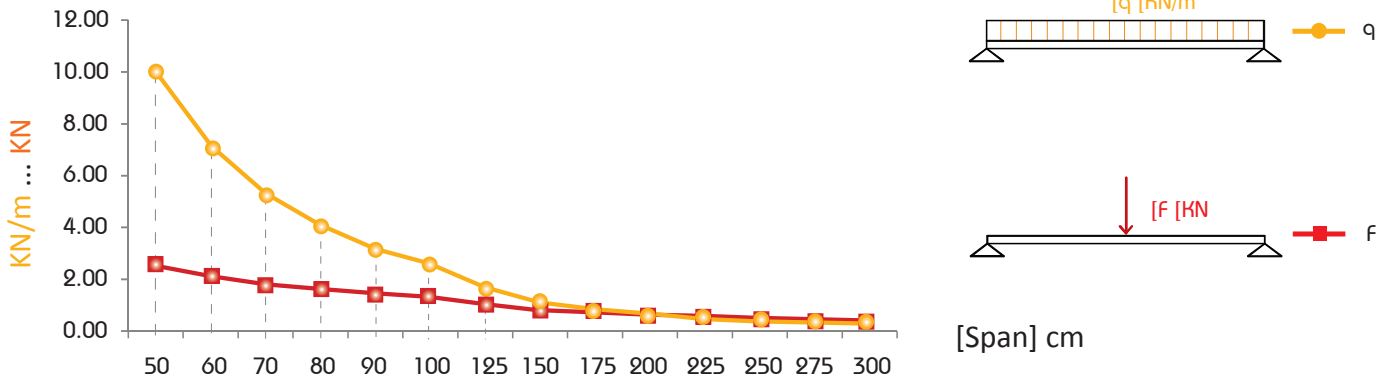

Deflection @ Allowable Uniform Load

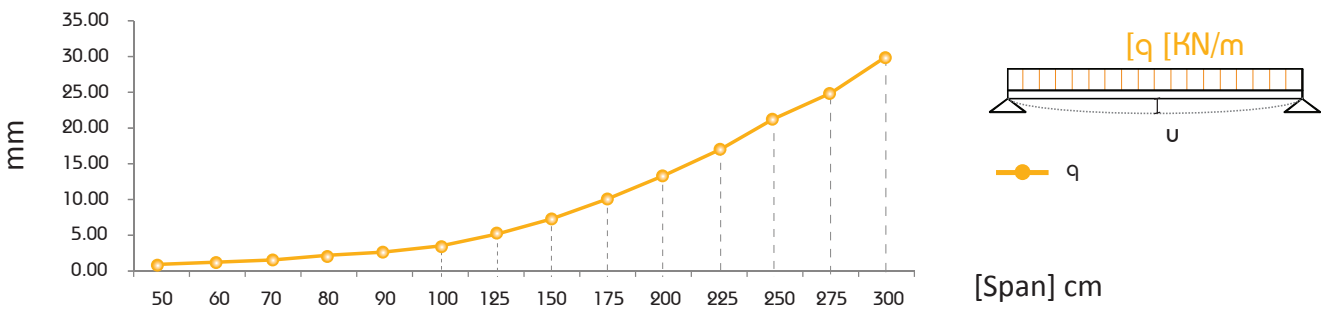

Uniform Load @ Allowable Deflection

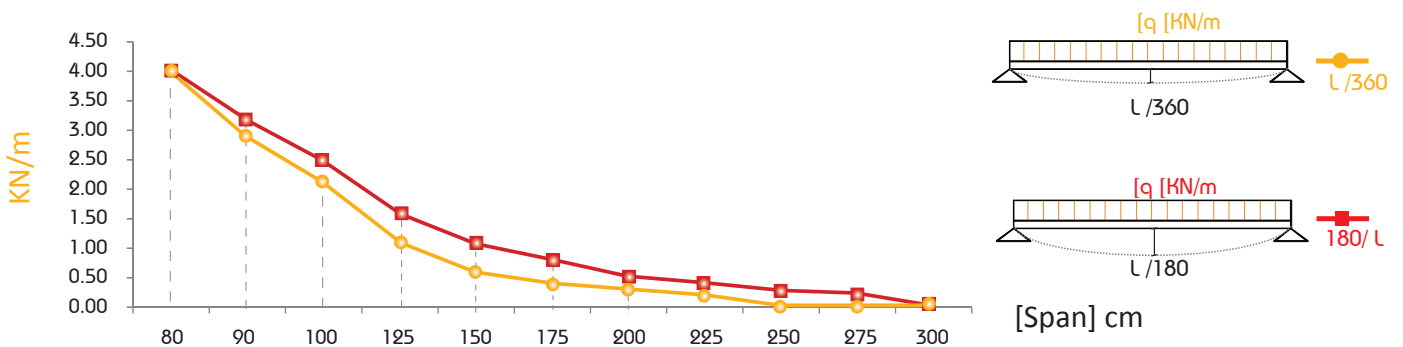

Load table for single beam with uniform (characteristic) Live-Load

This associated data are considered for perforated and non-perforated c-channel types according to DIN 18.800

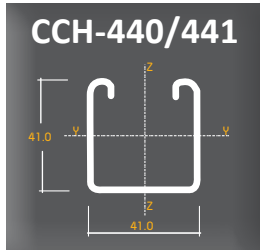

C-Channel:	41 x 41 x 2.5	
Cross Section Area (A)	2.95	cm ²
Moment of Inertia (I _y)	5.87	cm ⁴
Moment of Inertia (I _z)	8.76	cm ⁴
Self weight (G)	2.32	kg/m

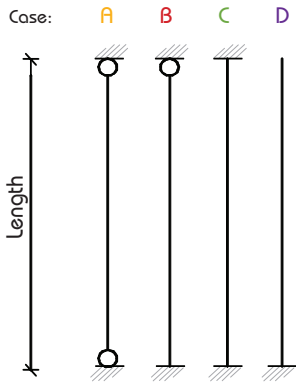

Span (L) [cm]	Allowable Central Load** [kN]			
	Case A	Case B	Case C	Case D
50	19.00	19.00	19.00	19.00
60	19.00	19.00	19.00	19.00
70	19.00	19.00	19.00	19.00
80	19.00	19.00	19.00	16.00
90	19.00	19.00	19.00	13.00
100	19.00	19.00	19.00	11.00
125	19.00	19.00	19.00	8.00
150	17.00	19.00	19.00	5.00
175	14.00	19.00	19.00	4.50
200	11.00	19.00	19.00	3.60
225	9.00	16.00	19.00	2.90
250	8.00	14.00	19.00	x
275	6.00	12.00	19.00	x
300	5.00	10.00	17.00	x

Column Load Data

Allowable Central Load**

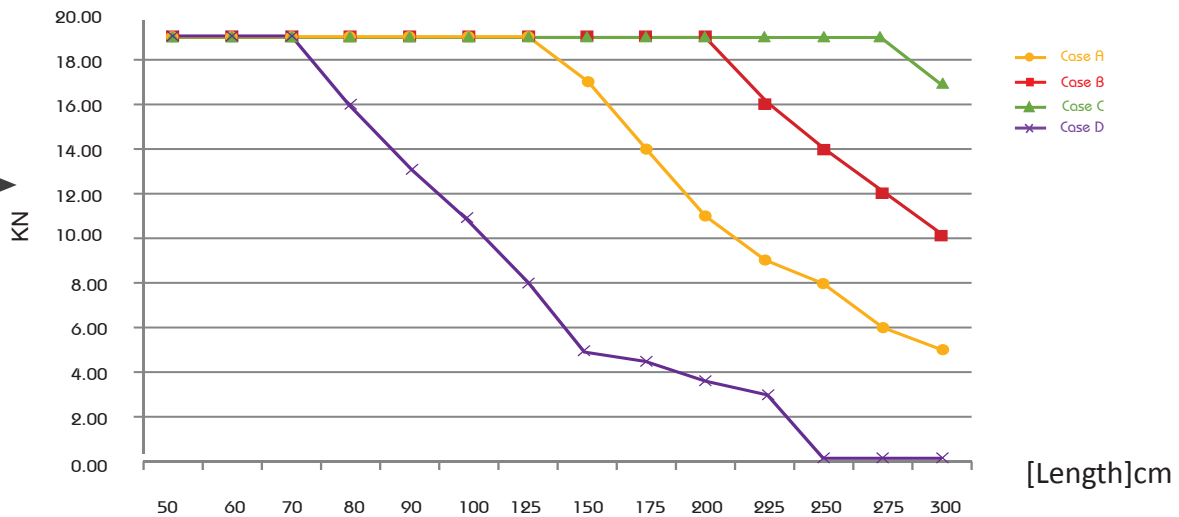

** Given loads are always "allowable characteristic live load"

Load table for single beam with uniform (characteristic) Live-Load

This associated data are considered for perforated and non-perforated c-channel types according to DIN 18.800

Thickness : 2.5 mm
 Standard Length : 3.00 m
 Finishes : Pre-Galvanized,
 Hot-Dip Galvanized.



C-Channel:	41x41x2.5 b2b	
Area of Shear (A_v)	2.37	cm ²
Moment of Inertia (I_y)	34.08	cm ⁴
Moment of Inertia (I_z)	17.56	cm ⁴
min. Section Modulus (S_y)	8.31	cm ³
Warping Constant (I_w)	140.95	cm ⁶
Torsional Constant (I_T)	0.16	cm ⁴
Plastic Moment cap. ($M_{pl,y}$)	2.51	kNm
Self weight (G)	4.70	kg/m

Chosen Material:	40 B = S 235 JRG2	
Allowable Bending Stress	21,82	kN/cm ²
Allowable Shear Stress	12,60	kN/cm ²
Modulus of Elasticity	21.000	kN/cm ²

Beam Load Data

Span (L) [cm]	Allowable Load*		Deflection U [mm]	[L / X]	Uniform Load* @	
	q [kN/m]	F [kN]			L / 360 q [kN/m]	L / 180 q [kN/m]
50	30.90	7.70	0.44	1.140	30.90	30.90
60	21.50	6.50	0.63	950	21.50	21.50
70	15.80	5.50	0.86	810	15.80	15.80
80	12.10	4.80	1.13	710	12.10	12.10
90	9.60	4.30	1.43	630	9.60	9.60
100	7.70	3.90	1.75	570	7.70	7.70
125	5.00	3.10	2.78	450	5.00	5.00
150	3.40	2.60	3.91	380	3.40	3.40
175	2.50	2.20	5.33	330	2.30	2.50
200	1.90	1.90	6.91	290	1.50	1.90
225	1.50	1.70	8.74	260	1.10	1.50
250	1.20	1.50	10.66	230	0.80	1.20
275	1.00	1.40	13.01	210	0.60	1.00
300	0.77	1.20	14.18	210	0.50	0.80

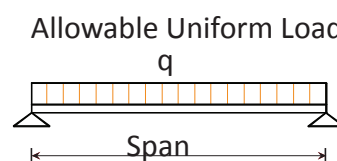
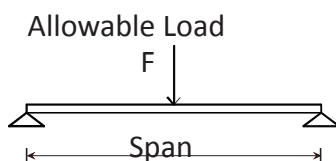

* Given loads are always "allowable characteristic live load"

BEAM LOADING GRAPH CCH-442

Allowable Loads

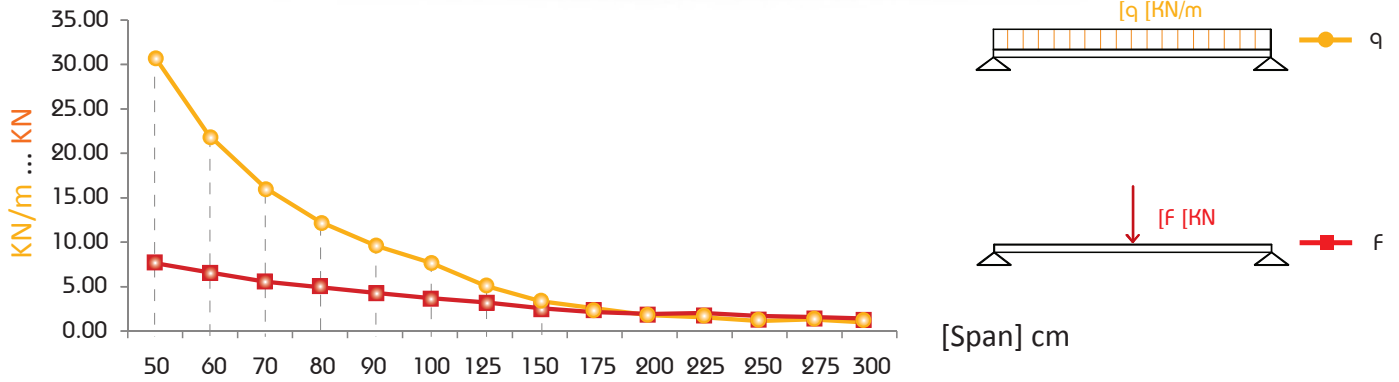

Deflection @ Allowable Uniform Load

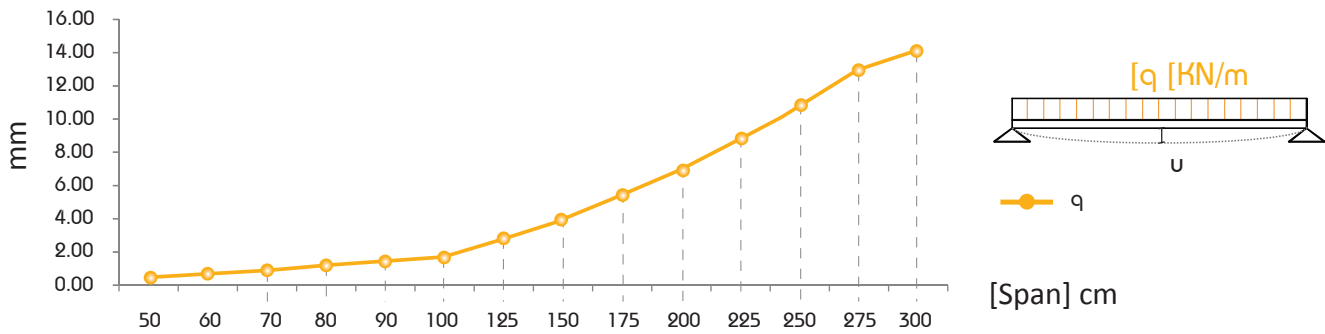

Uniform Load @ Allowable Deflection

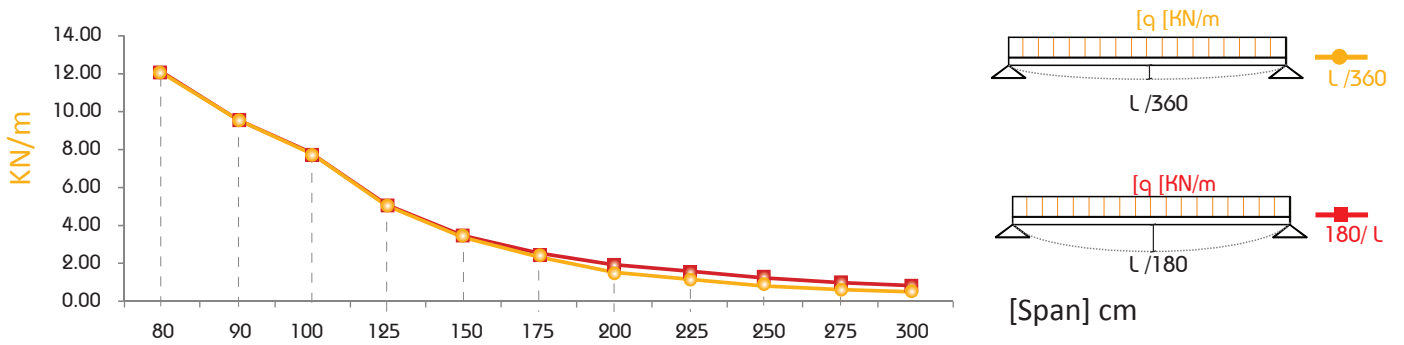

Load table for single beam with uniform (characteristic) Live-Load

This associated data are considered for perforated and non-perforated c-channel types according to DIN 18.800

C-Channel:	41 x 41 x 2.5 b2b	
Cross Section Area (A)	5.99	cm ²
Moment of Inertia (I _y)	34.08	cm ⁴
Moment of Inertia (I _z)	17.56	cm ⁴
Self weight (G)	4.70	kg/m

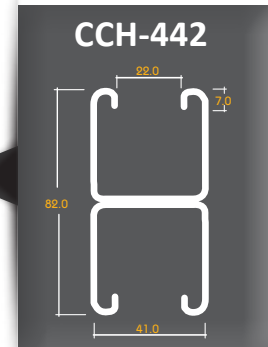

Span (L) [cm]	Allowable Central Load** [KN]			
	Case A	Case B	Case C	Case D
50	39.00	39.00	39.00	39.00
60	39.00	39.00	39.00	39.00
70	39.00	39.00	39.00	39.00
80	39.00	39.00	39.00	39.00
90	39.00	39.00	39.00	36.00
100	39.00	39.00	39.00	31.00
125	39.00	39.00	39.00	22.00
150	39.00	39.00	39.00	17.00
175	37.00	39.00	39.00	13.00
200	31.00	39.00	39.00	10.00
225	26.00	39.00	39.00	8.00
250	22.00	37.00	39.00	6.00
275	19.00	33.00	39.00	5.00
300	17.00	29.00	39.00	x

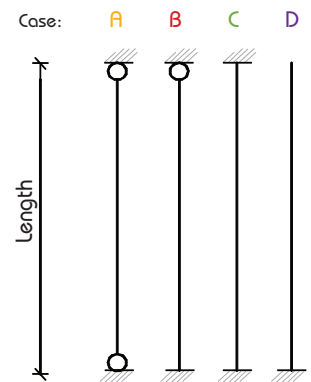

Column Load Data

Allowable Central ** Load

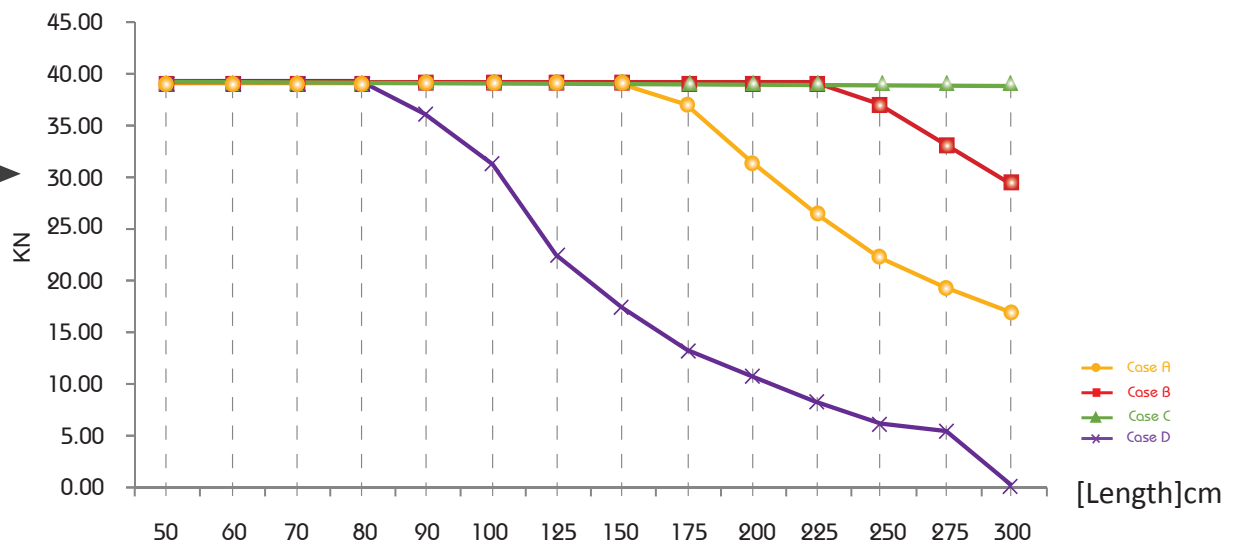

** Given loads are always "allowable characteristic live load"

CCH-460/461

Load table for single beam with uniform (characteristic) Live-Load

This associated data are considered for perforated and non-perforated c-channel types according to DIN 18.800

Thickness : 2.5 mm
 Standard Length : 3.00 m
 Finishes : Pre-Galvanized, Hot-Dip Galvanized.

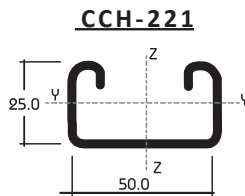

C-Channel:	50 x 25 x 2.5	
Area of Shear (A_z)	0.83	cm ²
Moment of Inertia (I_y)	1.78	cm ⁴
Moment of Inertia (I_z)	9.46	cm ⁴
min. Section Modulus (S_y)	1.25	cm ³
Warping Constant (I_w)	58.73	cm ⁶
Torsional Constant (I_t)	0.06	cm ⁴
Plastic Moment cap. ($M_{pl,y}$)	0.41	kNm
Self weight (G)	1.90	kg/m

Chosen Material:	S 235 JRG2	
Allowable Bending Stress	21,82	kN/cm ²
Allowable Shear Stress	12,60	kN/cm ²
Modulus of Elasticity	21.000	kN/cm ²

Beam Load Data

Span (L) [cm]	Allowable Load*		Deflection		Uniform Load* @	
					L / 360	L / 180
	q [kN/m]	F [kN]	U [mm]	[L/X]	q [kN/m]	q [kN/m]
30	12.90	1.90	0.40	750	12.90	12.90
40	7.30	1.50	0.72	560	7.30	7.30
50	4.70	1.20	1.13	440	4.70	4.70
60	3.20	1.00	1.60	380	3.00	3.20
70	2.40	0.80	2.23	310	1.90	2.40
80	1.80	0.72	2.85	280	1.25	1.82
90	1.40	0.63	3.57	250	0.88	1.44
100	1.20	0.60	4.67	210	0.64	1.16
125	0.74	0.46	7.10	180	0.33	0.65
150	0.52	0.39	10.46	140	0.19	0.38
175	0.38	0.33	14.34	120	x	0.24
200	0.29	0.29	18.94	110	x	x
225	0.23	0.26	24.45	90	x	x
250	0.19	0.24	31.28	80	x	x
275	x	x	x	x	x	x
300	x	x	x	x	x	x

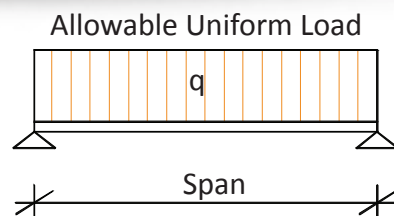
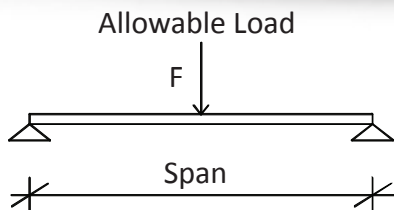

* Given loads are always "allowable characteristic live load"

BEAM LOADING GRAPH CCH-460/461

Allowable Loads

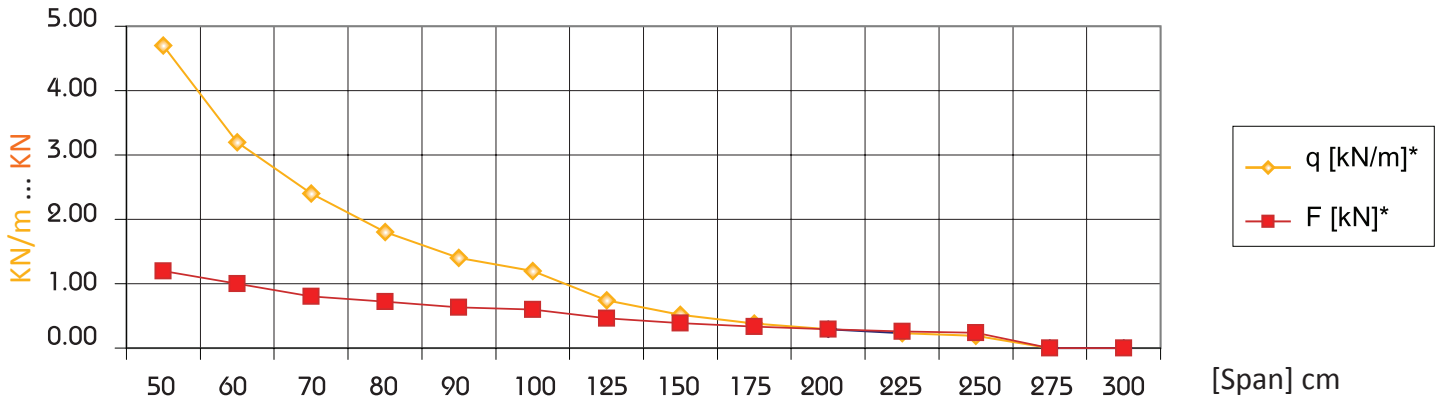

Deflection @ Allowable Uniform Load

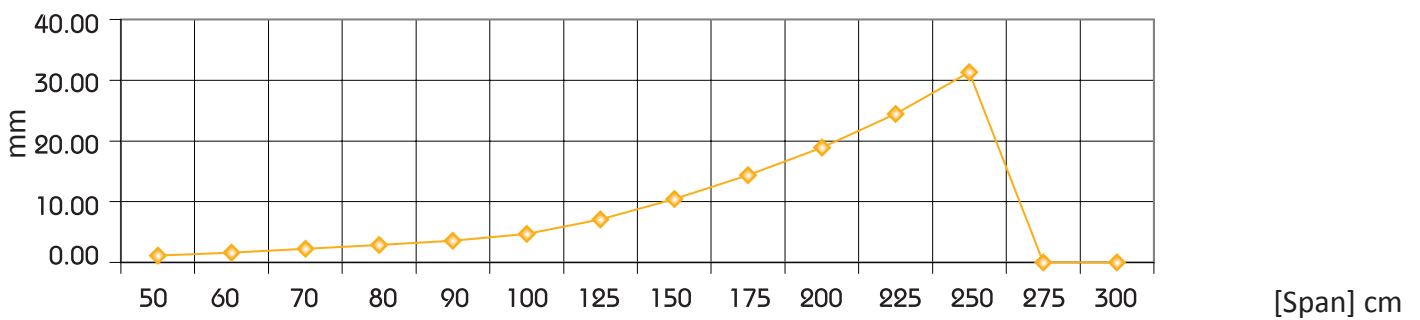

Uniform Load @ Allowable Deflection

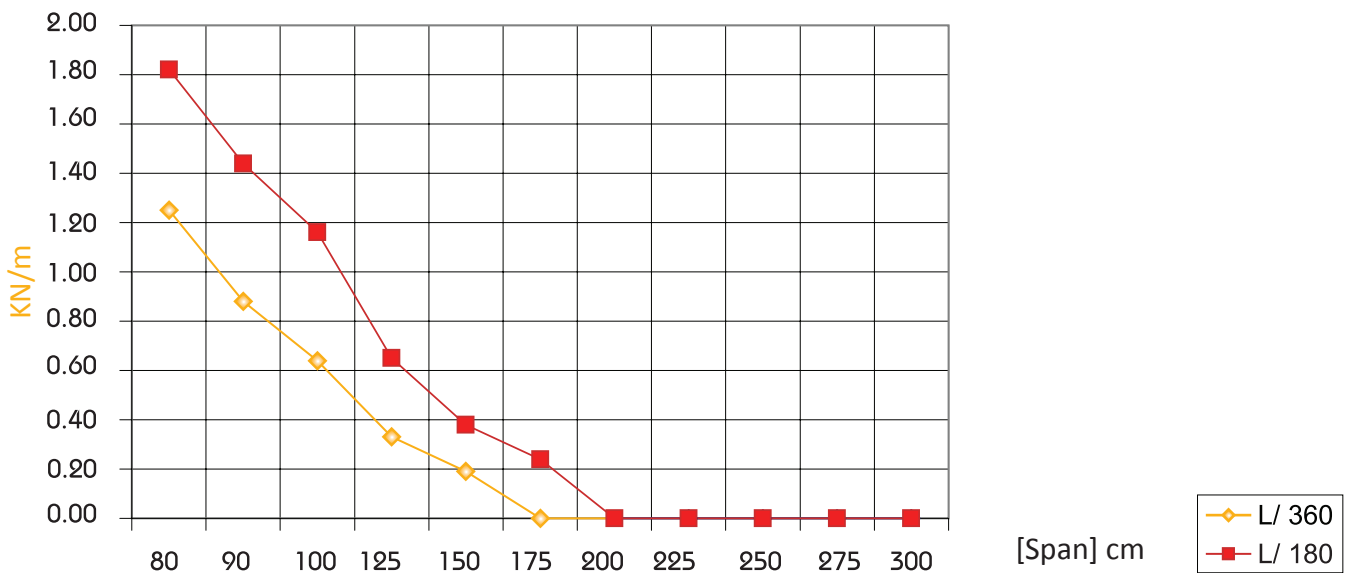

Load table for single beam with uniform (characteristic) Live-Load

This associated data are considered for perforated and non-perforated c-channel types according to DIN 18.800

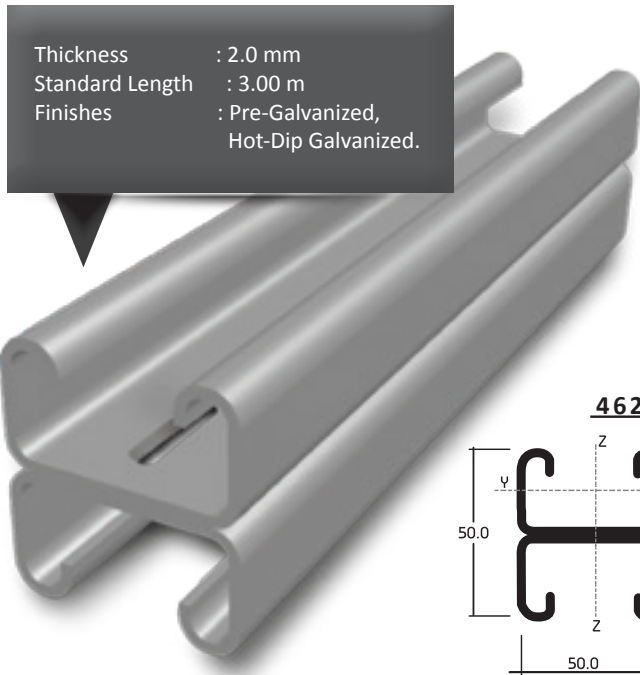

C-Channel:	50 x 25 x 2.0 b2b	
Area of Shear (A_z)	1.72	cm ²
Moment of Inertia (I_y)	8.93	cm ⁴
Moment of Inertia (I_z)	18.93	cm ⁴
min. Section Modulus (S_y)	3.57	cm ³
Warping Constant (I_w)	49.43	cm ⁶
Torsional Constant (I_t)	0.11	cm ⁴
Plastic Moment cap. ($M_{pl,y}$)	1.09	kNm
Self weight (G)	3.70	kg/m

Chosen Material:	S 235 JRG2	
Allowable Bending Stress	21.28	kN/cm ²
Allowable Shear Stress	12.60	kN/cm ²
Modulus of Elasticity	21.000	kN/cm ²

Beam Load Data

Span (L) [cm]	Allowable Load*		Deflection U [mm]	[L/X]	Uniform Load* @	
	q [kN/m]	F [kN]			L / 360 q [kN/m]	L / 180 q [kN/m]
50	13,30	3,30	0,64	790	13,30	13,30
60	9,20	2,80	0,91	660	9,20	9,20
70	6,80	2,40	1,25	560	6,80	6,80
80	5,20	2,10	1,64	490	5,20	5,20
90	4,10	1,80	2,07	430	4,10	4,10
100	3,30	1,70	2,55	390	3,20	3,30
125	2,10	1,30	3,98	310	1,60	2,10
150	1,50	1,10	5,94	250	0,90	1,50
175	1,10	1,00	8,14	210	0,60	1,10
200	0,80	0,80	10,23	200	0,40	0,80
225	0,66	0,74	13,64	160	0,28	0,56
250	0,53	0,66	16,92	150	0,20	0,41
275	0,44	0,61	20,84	130	x	0,31
300	0,37	0,56	25,18	120	x	0,24

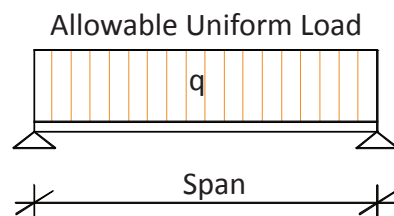
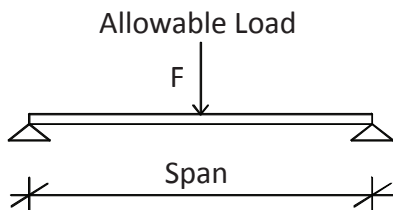

* Given loads are always "allowable characteristic live load"

BEAM LOADING GRAPH CCH-462

Allowable Loads

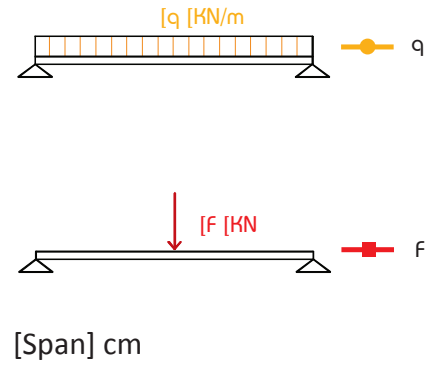
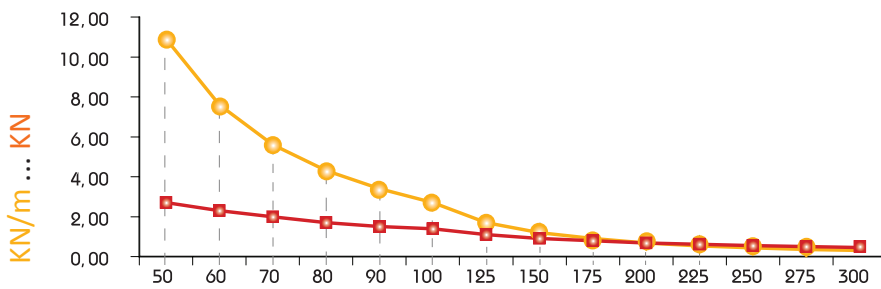

Deflection @ Allowable Uniform Load

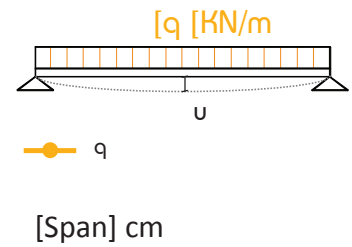
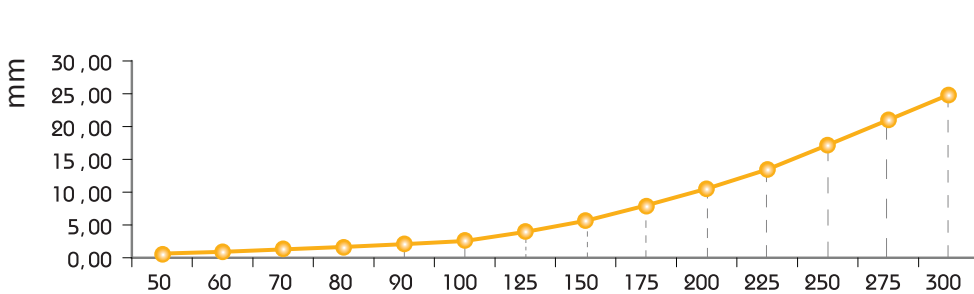

Uniform Load @ Allowable Deflection

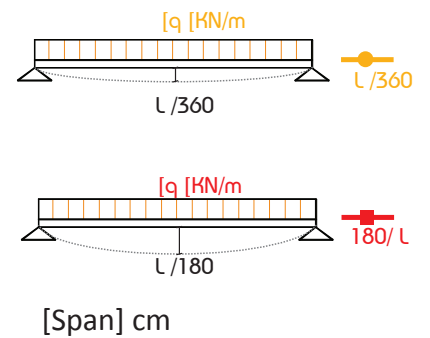
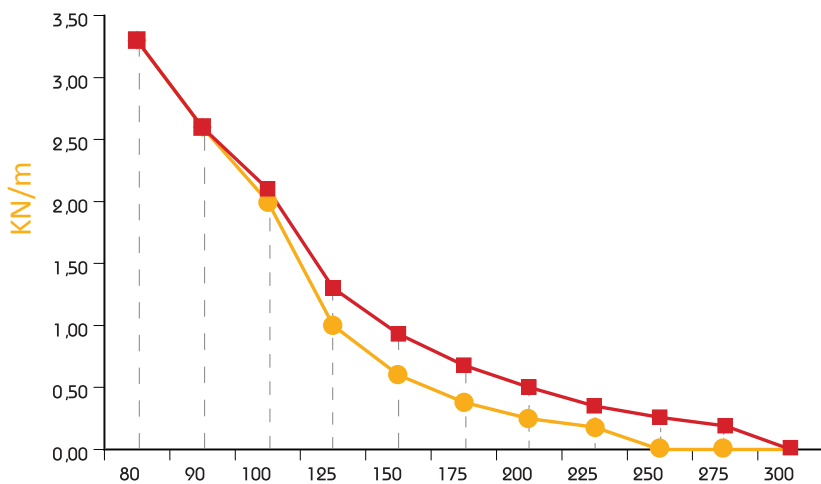

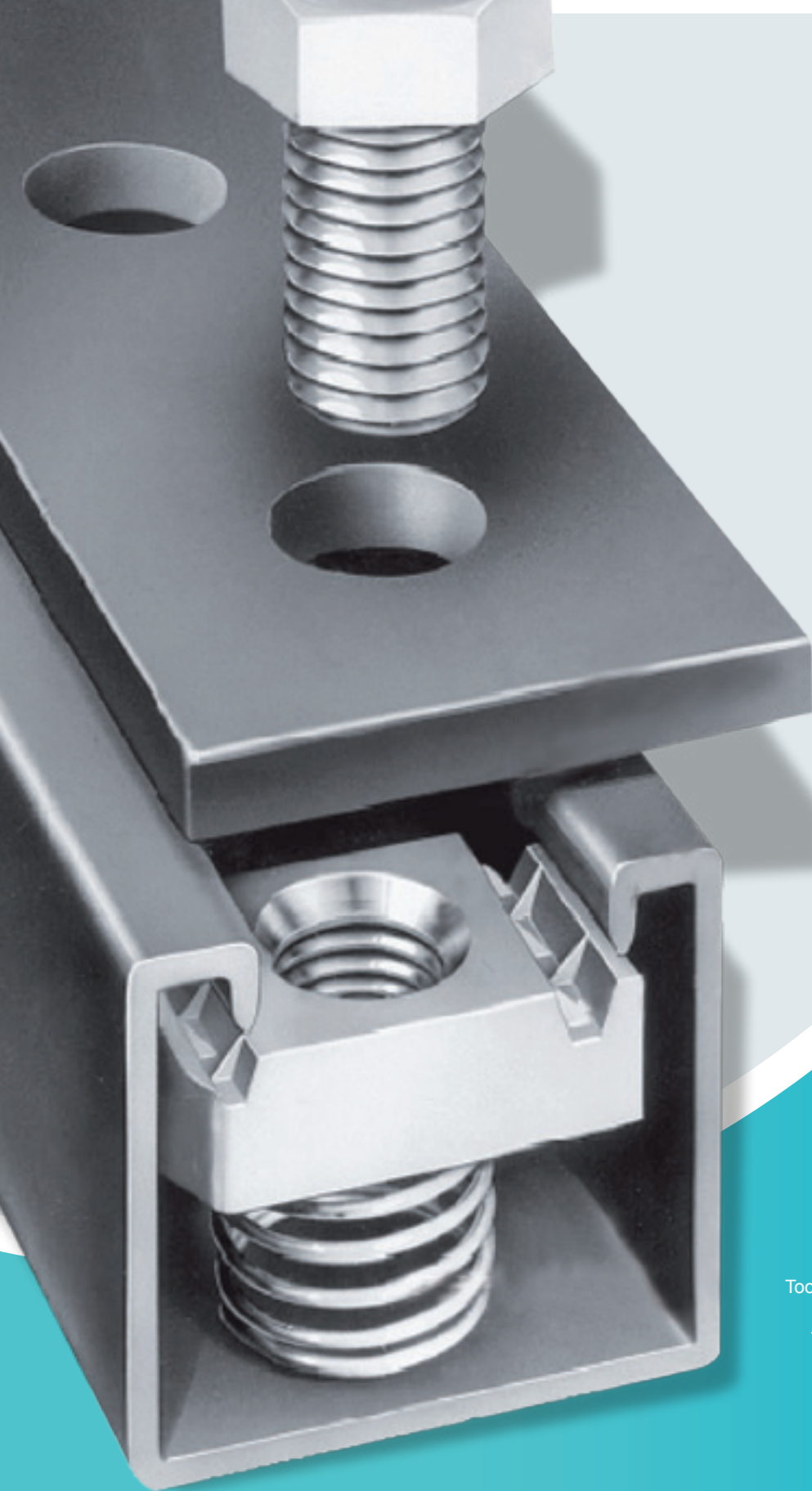

Toothed channels provide shock-resistant fixing for non-slip connections and higher safety requirements. To make fitting easier, the locking plates and T-head bolts should be pre-mounted on the fittings to be attached.

TOOTHED CHANNELS

TOOTHED CHANNEL

CCH-220T/221T (41x21x1.5)

Thickness : 1.5 mm
 Standard Length : 3.00 m
 Finishes : Pre-Galvanized,
 Hot-Dip Galvanized.



Due to its positive locking feature, this channel is ideally suited when increased loading capacities in longitudinal direction are required.

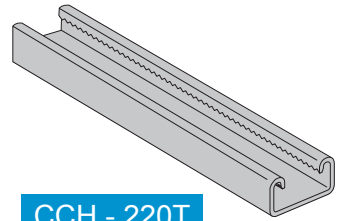

CCH - 220T

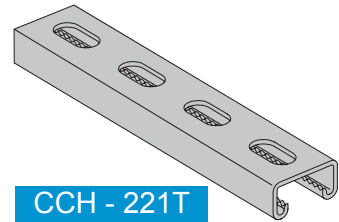

CCH - 221T

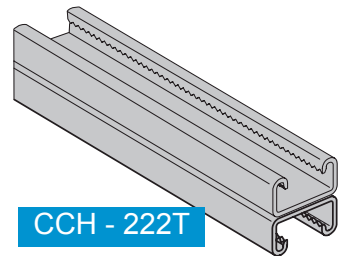

CCH - 222T

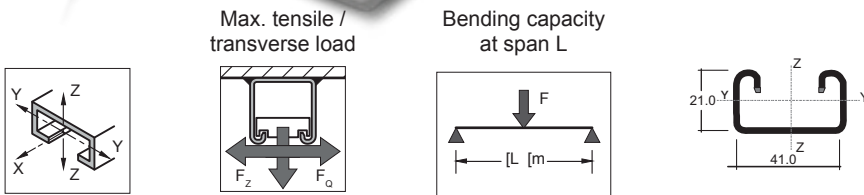

Channel CCH	Channel Weight G [Kg/m]	Cross Section A [cm ²]	Moment of inertia		Section modulus		Bending capacity at span L		
			I _y [cm ⁴]	I _z [cm ⁴]	W _y [cm ³]	W _z [cm ³]	m 0.50	m 1.00	m 1.50
220T	1.09	1.39	0.81	3.36	0.64	1.91	1.12	0.56	0.19
221T	0.97	1.23	0.70	3.34	0.60	1.70	1.04	0.52	0.17
222T	1.94	2.47	3.55	6.69	1.69	3.82	2.94	1.47	0.49

CCH-240T/241T (41x41x1.5)

Thickness : 1.5 mm
 Standard Length : 3.00 m
 Finishes : Pre-Galvanized,
 Hot-Dip Galvanized.

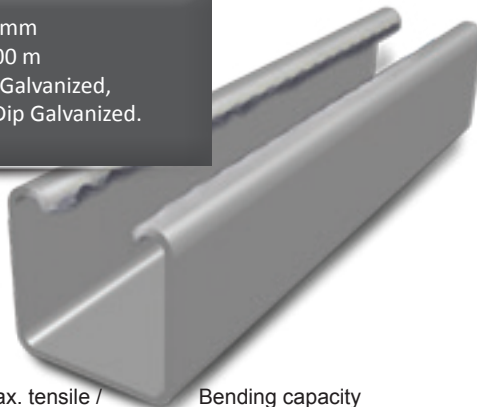

Due to its positive locking feature, this channel is ideally suited when increased loading capacities in longitudinal direction are required.

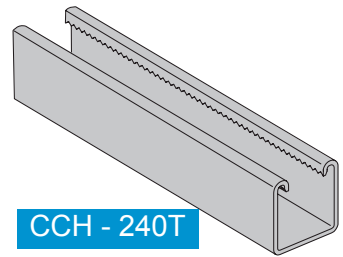

CCH - 240T

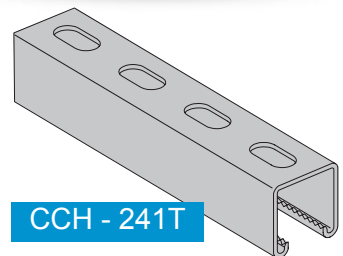

CCH - 241T

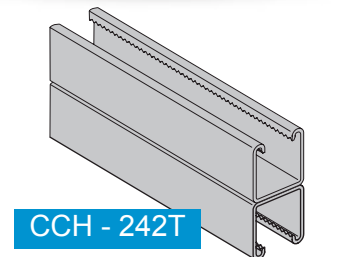

CCH - 242T

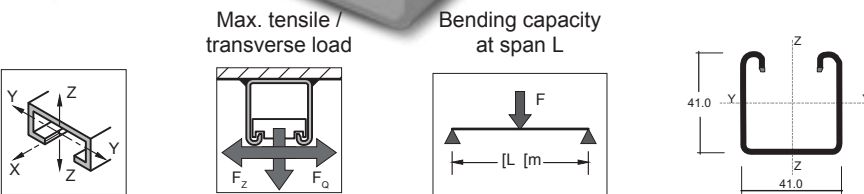

Channel CCH	Channel Weight G [Kg/m]	Cross Section A [cm ²]	Moment of inertia		Section modulus		Bending capacity at span L		
			I _y [cm ⁴]	I _z [cm ⁴]	W _y [cm ³]	W _z [cm ³]	m 0.50	m 1.00	m 1.50
240T	1.56	1.99	4.36	5.70	1.86	2.99	3.24	1.62	1.08
241T	1.44	1.83	3.87	5.68	1.76	2.66	3.06	1.53	1.02
242T	2.88	3.67	21.11	11.37	5.15	5.98	8.98	4.49	2.90

TOOTHED CHANNEL

CCH-320T/321T (41x21x2.0)

Thickness : 1.5 mm
 Standard Length : 3.00 m
 Finishes : Pre-Galvanized,
 Hot-Dip Galvanized.

Due to its positive locking feature, this channel is ideally suited when increased loading capacities in longitudinal direction are required

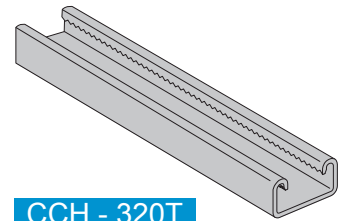

CCH - 320T

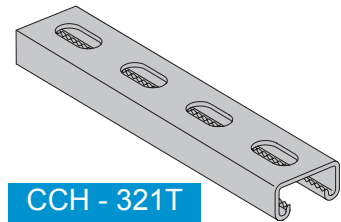

CCH - 321T

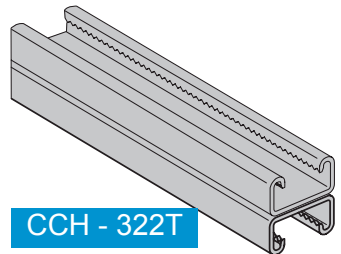

CCH - 322T

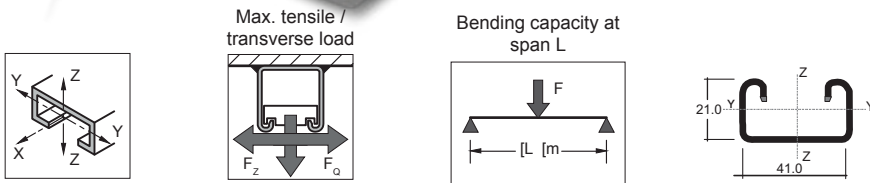

Channel CCH	Channel Weight G [Kg/m]	Cross Section A [cm ²]	Moment of inertia		Section modulus		Bending capacity at span L		
			I _y [cm ⁴]	I _z [cm ⁴]	W _y [cm ³]	W _z [cm ³]	m 0.50	m 1.00	m 1.50
							[F [KN]		
320T	1.44	1.83	0.99	4.77	0.84	2.37	1.46	0.73	0.24
321T	1.27	1.62	0.88	4.25	0.75	2.11	1.30	0.65	0.22
322T	2.54	3.24	4.60	8.51	2.19	4.74	3.80	1.91	1.27

CCH-340T/341T (41x41x2.0)

Thickness : 1.5 mm
 Standard Length : 3.00 m
 Finishes : Pre-Galvanized,
 Hot-Dip Galvanized.

Due to its positive locking feature, this channel is ideally suited when increased loading capacities in longitudinal direction are required

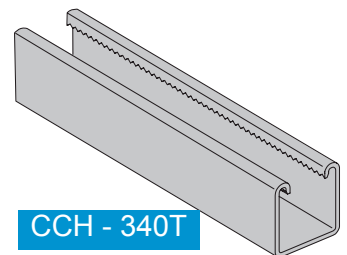

CCH - 340T

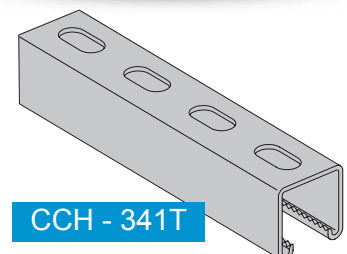

CCH - 341T

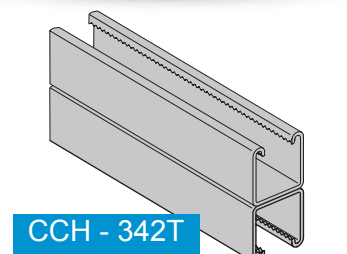

CCH - 342T

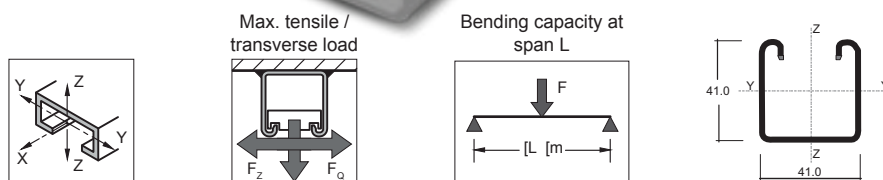

Channel CCH	Channel Weight G [Kg/m]	Cross Section A [cm ²]	Moment of inertia		Section modulus		Bending capacity at span L		
			I _y [cm ⁴]	I _z [cm ⁴]	W _y [cm ³]	W _z [cm ³]	m 0.50	m 1.00	m 1.50
							[F [KN]		
340T	2.04	2.60	5.41	7.03	2.35	3.86	4.10	2.05	1.37
341T	1.83	2.33	4.59	6.99	2.18	3.43	3.80	1.90	1.26
342T	3.76	4.79	26.81	14.04	6.62	7.72	11.54	5.77	3.85

TOOTHED CHANNEL

CCH-420T/421T (41x21x2.5)

Thickness : 2.5 mm
 Standard Length : 3.00 m
 Finishes : Pre-Galvanized,
 Hot-Dip Galvanized.

Due to its positive locking feature, this channel is ideally suited when increased loading capacities in longitudinal direction are required

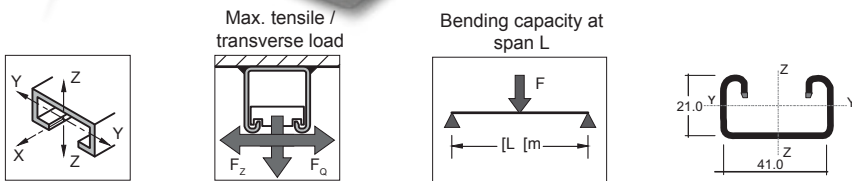
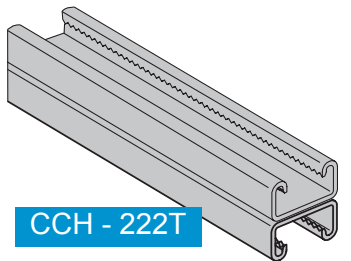
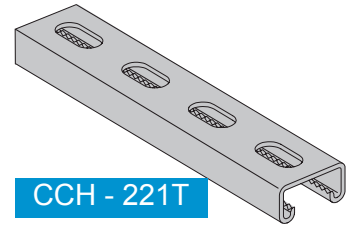
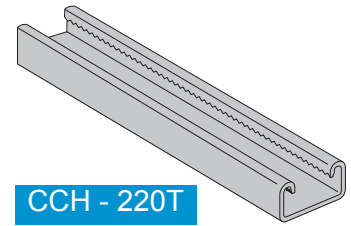

Channel CCH	Channel Weight G [Kg/m]	Cross Section A [cm ²]	Moment of inertia		Section modulus		Bending capacity at span L		
			I _y [cm ⁴]	I _z [cm ⁴]	W _y [cm ³]	W _z [cm ³]	m 0.50	m 1.00	m 1.50
420T	1.75	2.18	1.15	4.92	0.89	2.50	1.55	0.78	0.32
421T	1.54	1.95	1.01	4.99	0.86	2.49	1.5	0.75	0.3
422T	3.50	4.48	5.55	10.15	2.63	5.31	4.58	2.29	1.53

CCH-440T/441T (41x41x2.5)

Thickness : 2.5 mm
 Standard Length : 3.00 m
 Finishes : Pre-Galvanized,
 Hot-Dip Galvanized.

Due to its positive locking feature, this channel is ideally suited when increased loading capacities in longitudinal direction are required

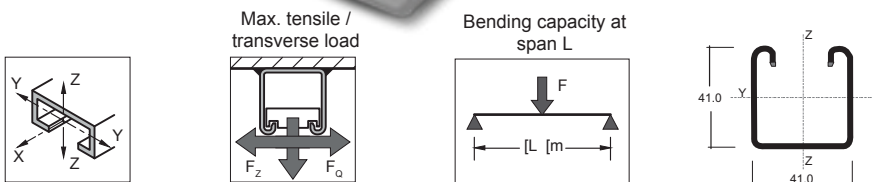
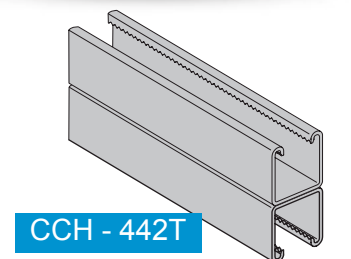
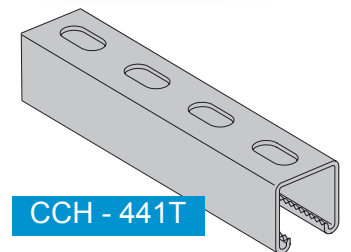
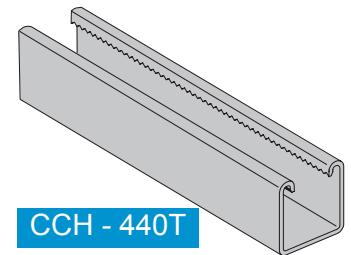

Channel CCH	Channel Weight G [Kg/m]	Cross Section A [cm ²]	Moment of inertia		Section modulus		Bending capacity at span L		
			I _y [cm ⁴]	I _z [cm ⁴]	W _y [cm ³]	W _z [cm ³]	m 0.50	m 1.00	m 1.50
440T	2.57	3.28	6.52	8.78	2.76	4.39	4.81	2.41	1.60
441T	2.30	2.91	5.62	8.74	2.57	4.35	4.48	2.24	1.49
442T	4.90	6.34	32.02	17.54	8.11	8.85	14.14	7.07	4.71

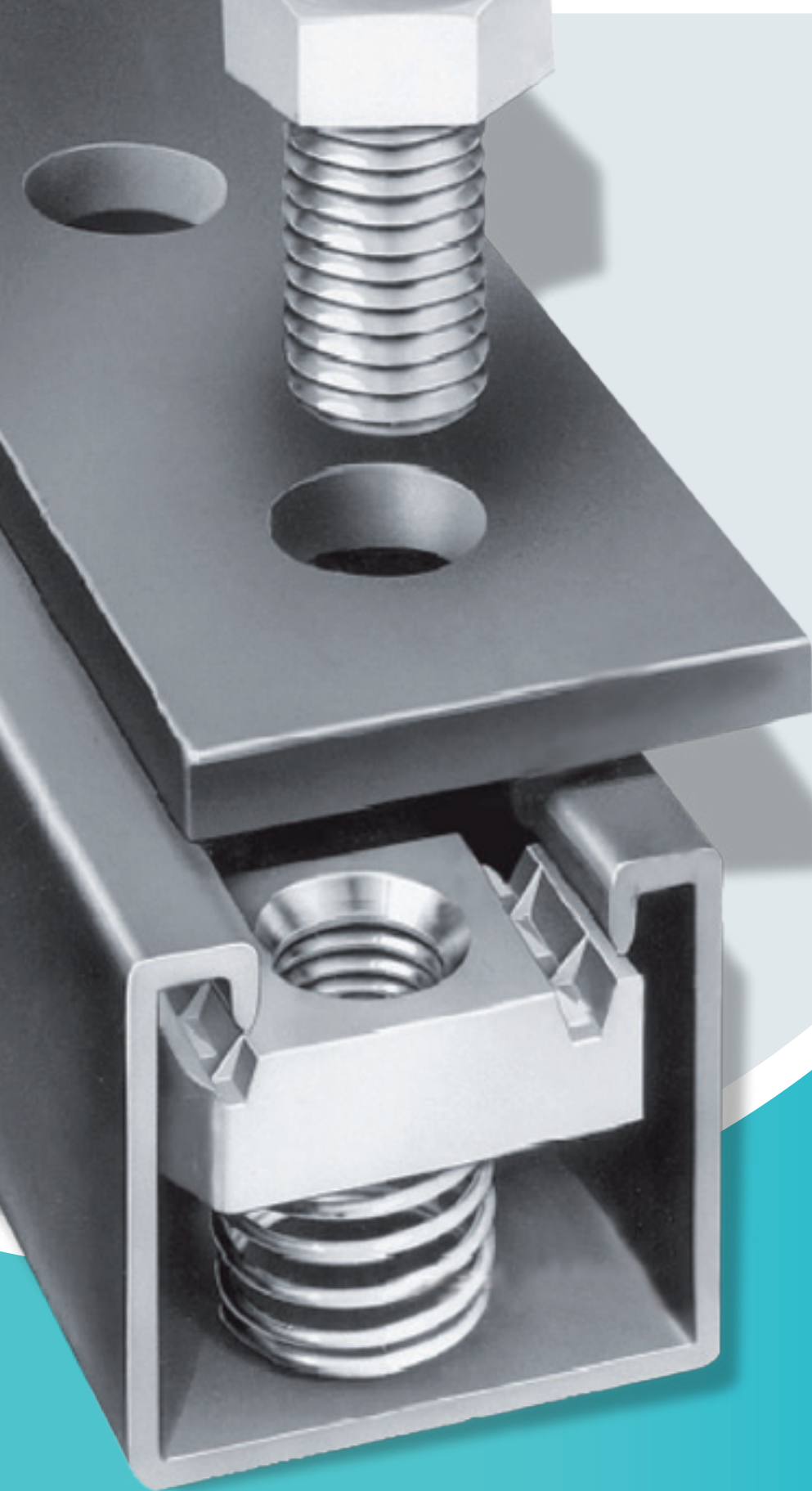

FITTINGS

This part offers a full section of fittings and accessories to complete SFSP's metal framing system.

Standard Finishes: Hot Dip Galvanized .

Fitting Specifications (unless noted): Hole Size 13.0mm Diameter; Hole Spacing 20.0mm from end and 48.0 mm on center; Width 41.0mm; Thickness, 6.0mm (Order hardware separately).

Square Washer

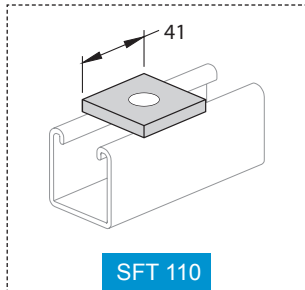

Splice Plate

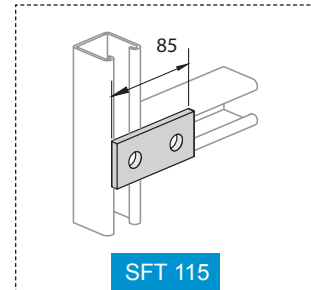

Splice Plate

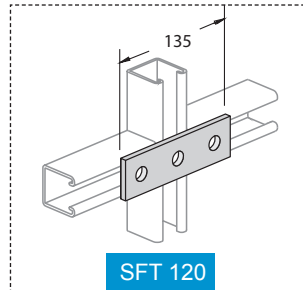

Splice Plate

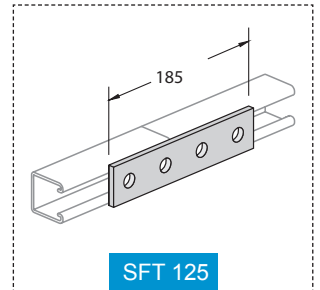

Splice Plate

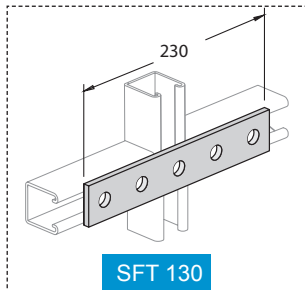

Splice Plate

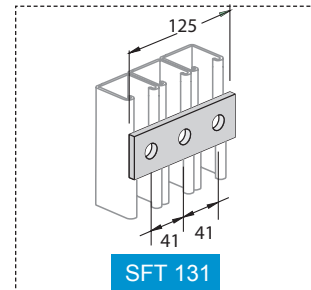

Square Splice Plate

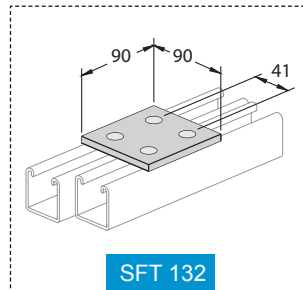

Angle Plate

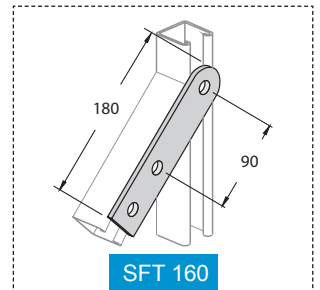

Angle Plate

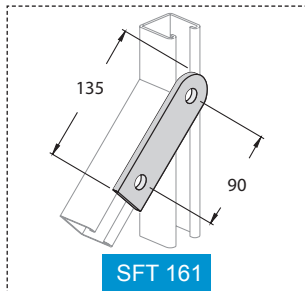

L - Plate

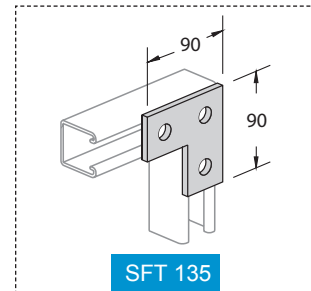

L - Plate

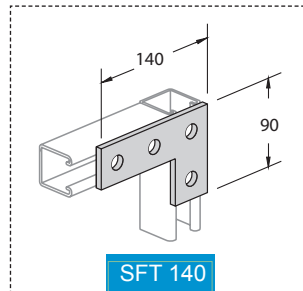

T - Plate

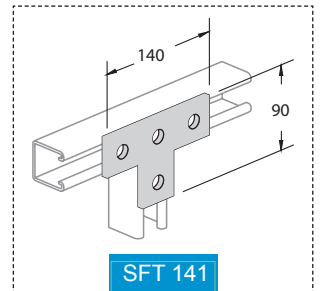

Plus Plate

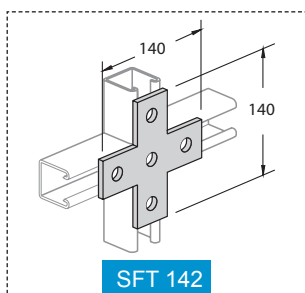

T - Plate

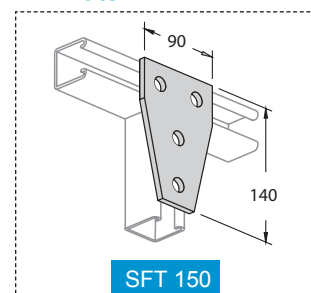

T - Plate

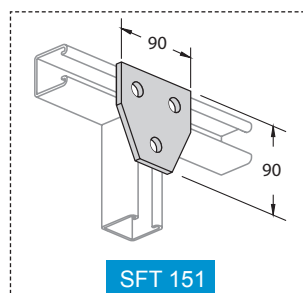

T - Plate

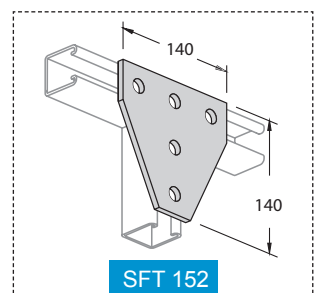

T - Plate

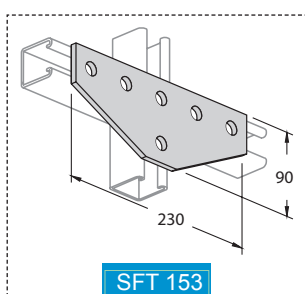

Plus Plate

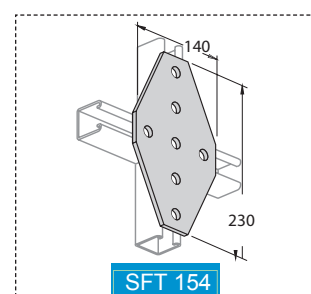

45° Plate

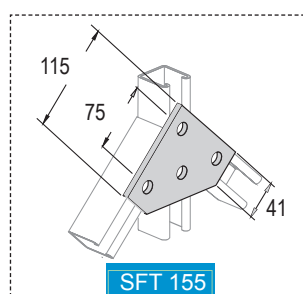

90° Plate

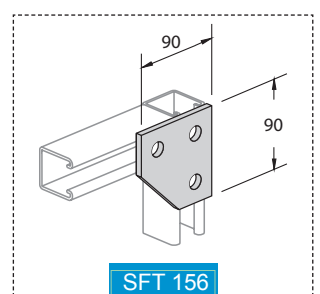

90° Plate

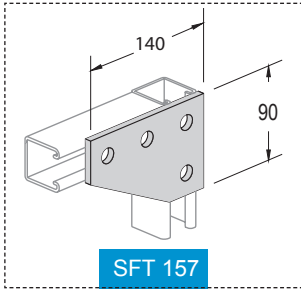

90° Plate

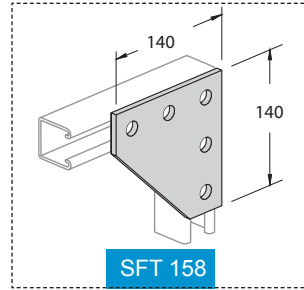

L - Bracket

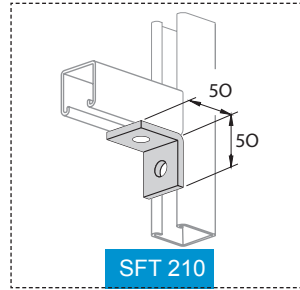

L - Bracket

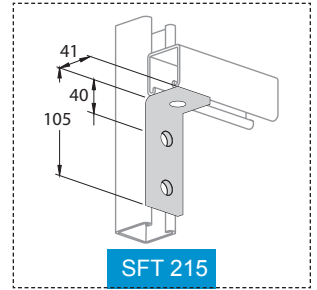

L - Bracket

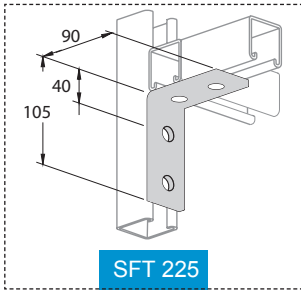

L - Bracket

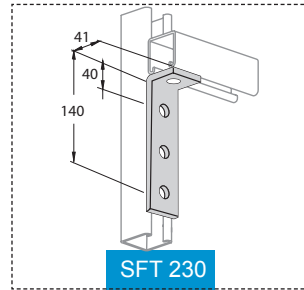

L - Plate

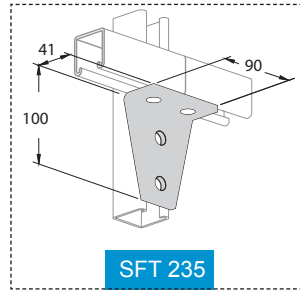

L - Plate

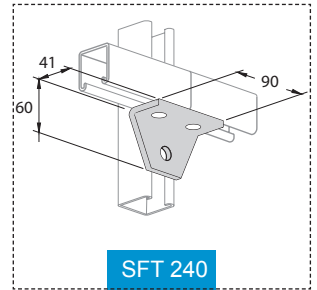

Angle Plate

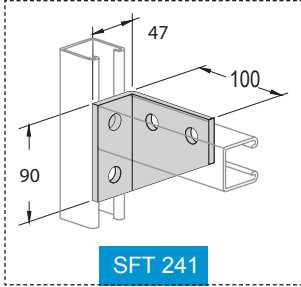

Angle Plate

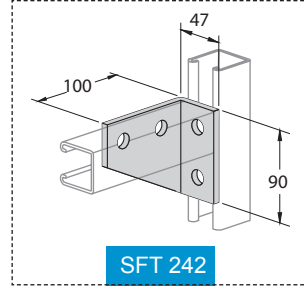

Angle Plate

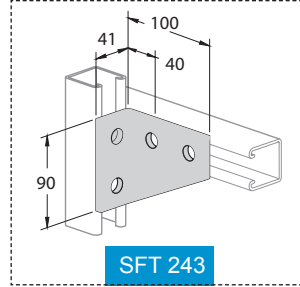

Angle Plate

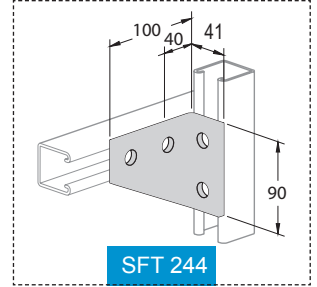

Angle Plate

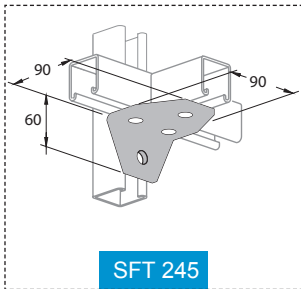

Angle Plate

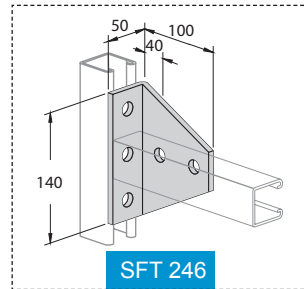

Angle Plate

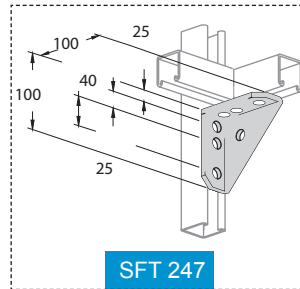

Angle Plate

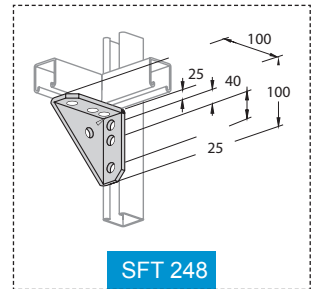

Angle Plate

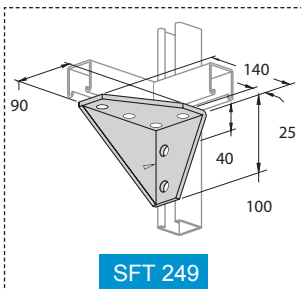

Angle Plate

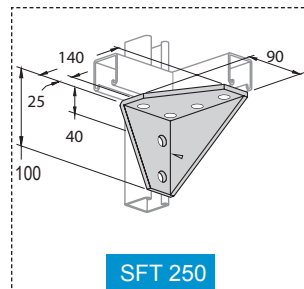

Angular Bracket

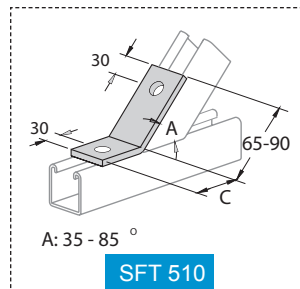

Angular Bracket

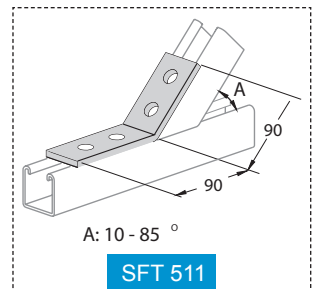

Angular Bracket

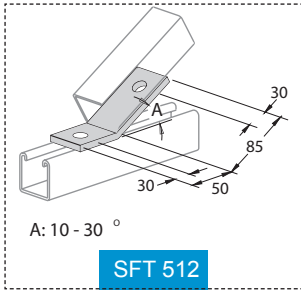

Angular Bracket

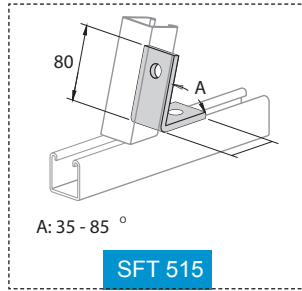

T - Corner Left

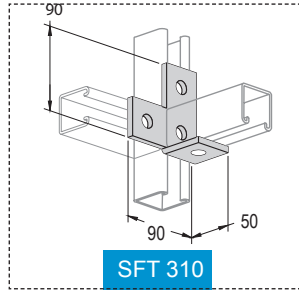

T - Corner Right

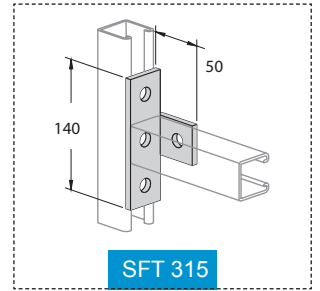

T - Center

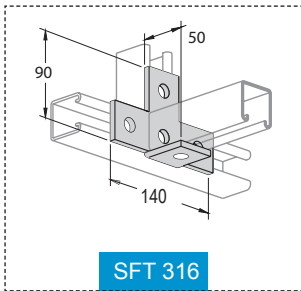

T - Corner Right

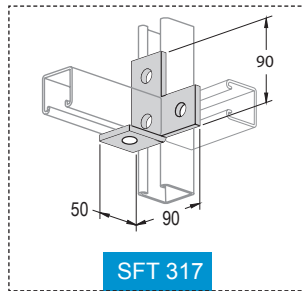

Double Wing Joint

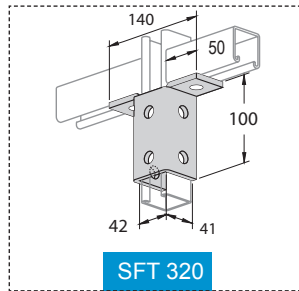

Double Wing Joint

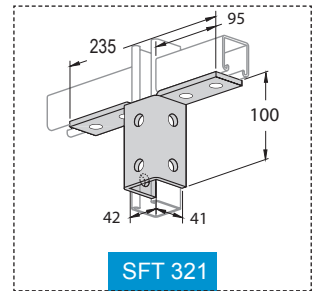

Double Wing Joint

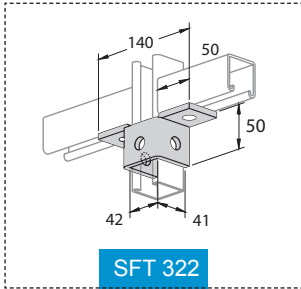

U & Wing Bracket

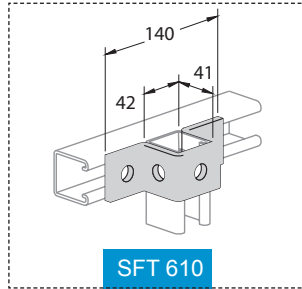

U & Wing Bracket

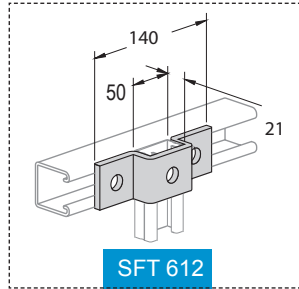

U & Wing Bracket

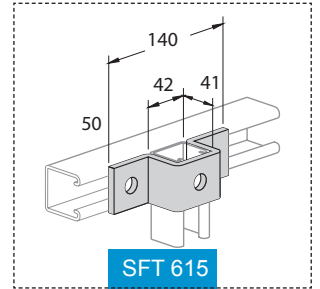

U & Wing Bracket

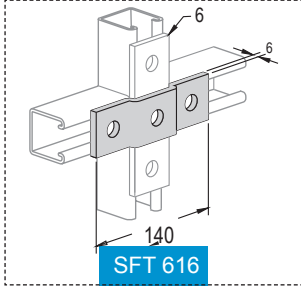

U & Wing Bracket

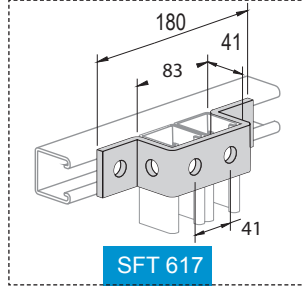

U & Wing Bracket

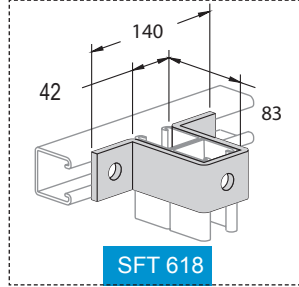

U & Wing Bracket

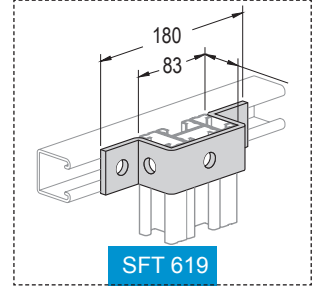

U & Wing Bracket

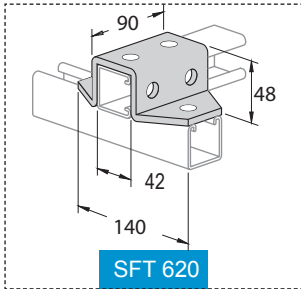

U & Wing Bracket

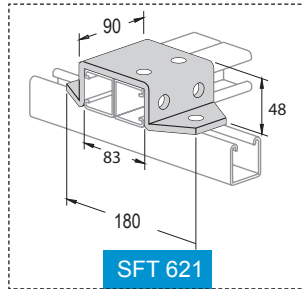

Single Channel Gusseted Bracket

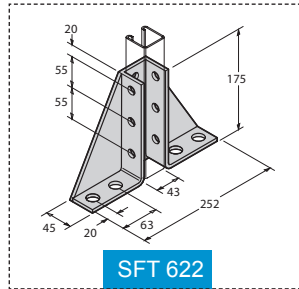

Double Channel Gusseted Bracket

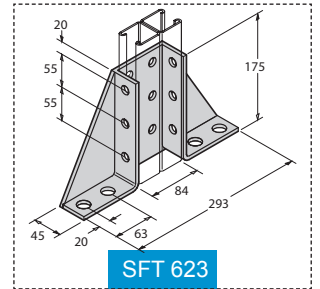

Beam Clamp

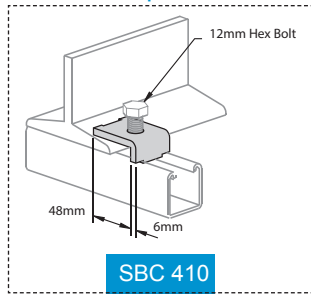

SBC 410

Beam Clamp

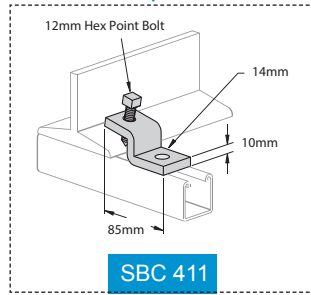

SBC 411

Beam Clamp

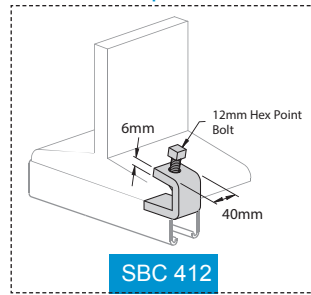

SBC 412

Beam Clamp

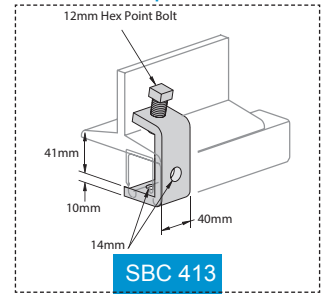

SBC 413

Beam Clamp

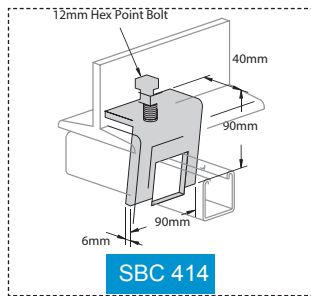

SBC 414

Beam Clamp

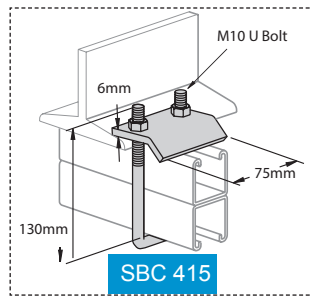

SBC 415

Beam Clamp

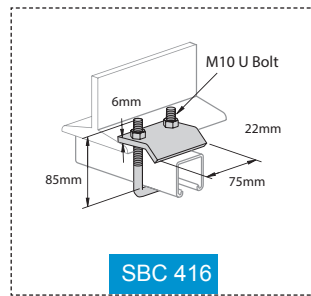

SBC 416

Beam Clamp

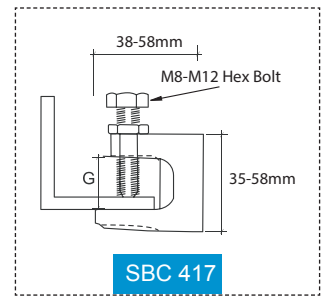

SBC 417

U - Joint Bracket

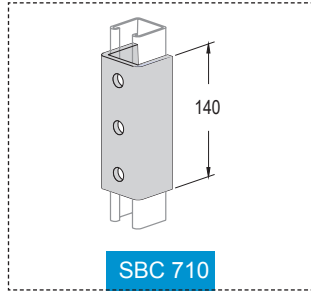

SBC 710

U - Joint Bracket

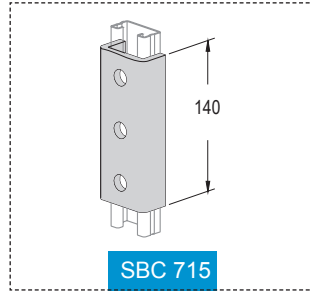

SBC 715

U - Joint Bracket

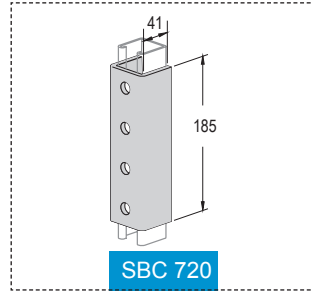

SBC 720

Plastic End Caps For Channels

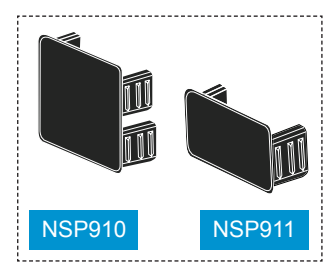

NSP910

NSP911

Post Base

Base Plate with Single Fix

SFT 340

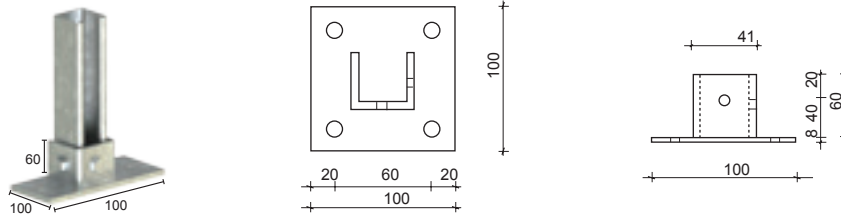

Base Plate with Double Fix

SFT 345

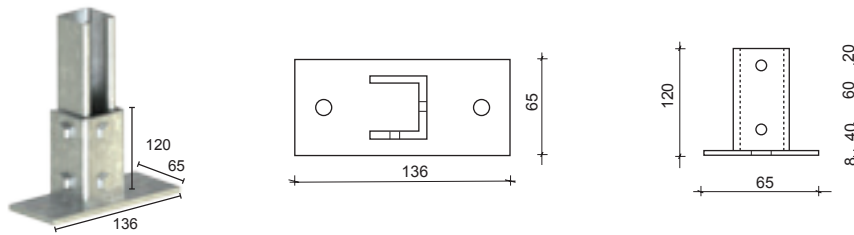

Base Plate with Double Fix

SFT 346

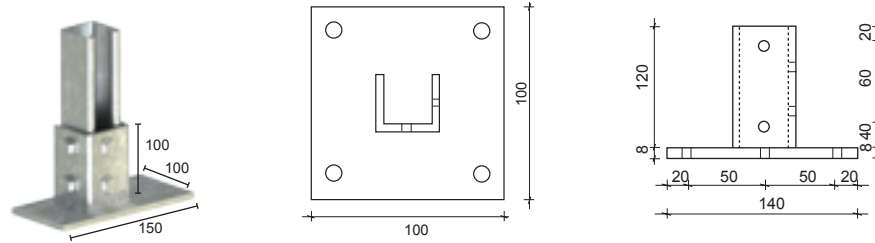

Base Plate with Double Channel

SFT 350

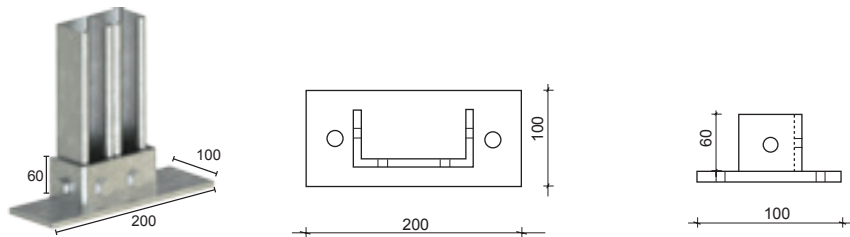

Base Plate with Double Channel Double Fix

SFT 355

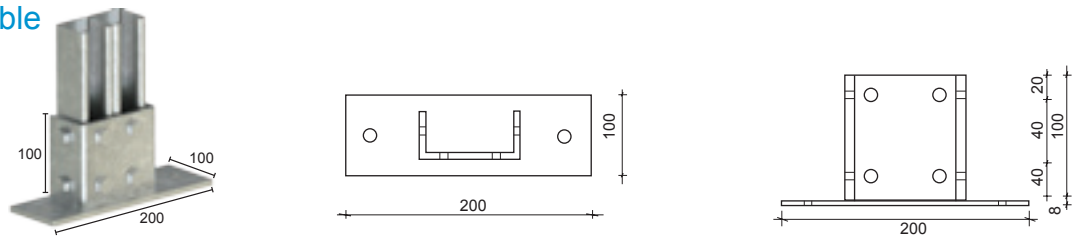

Base Plate with Double Channel Double Fix

SFT 356

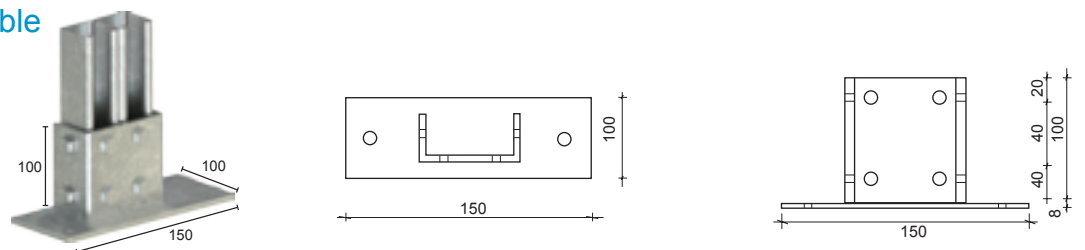

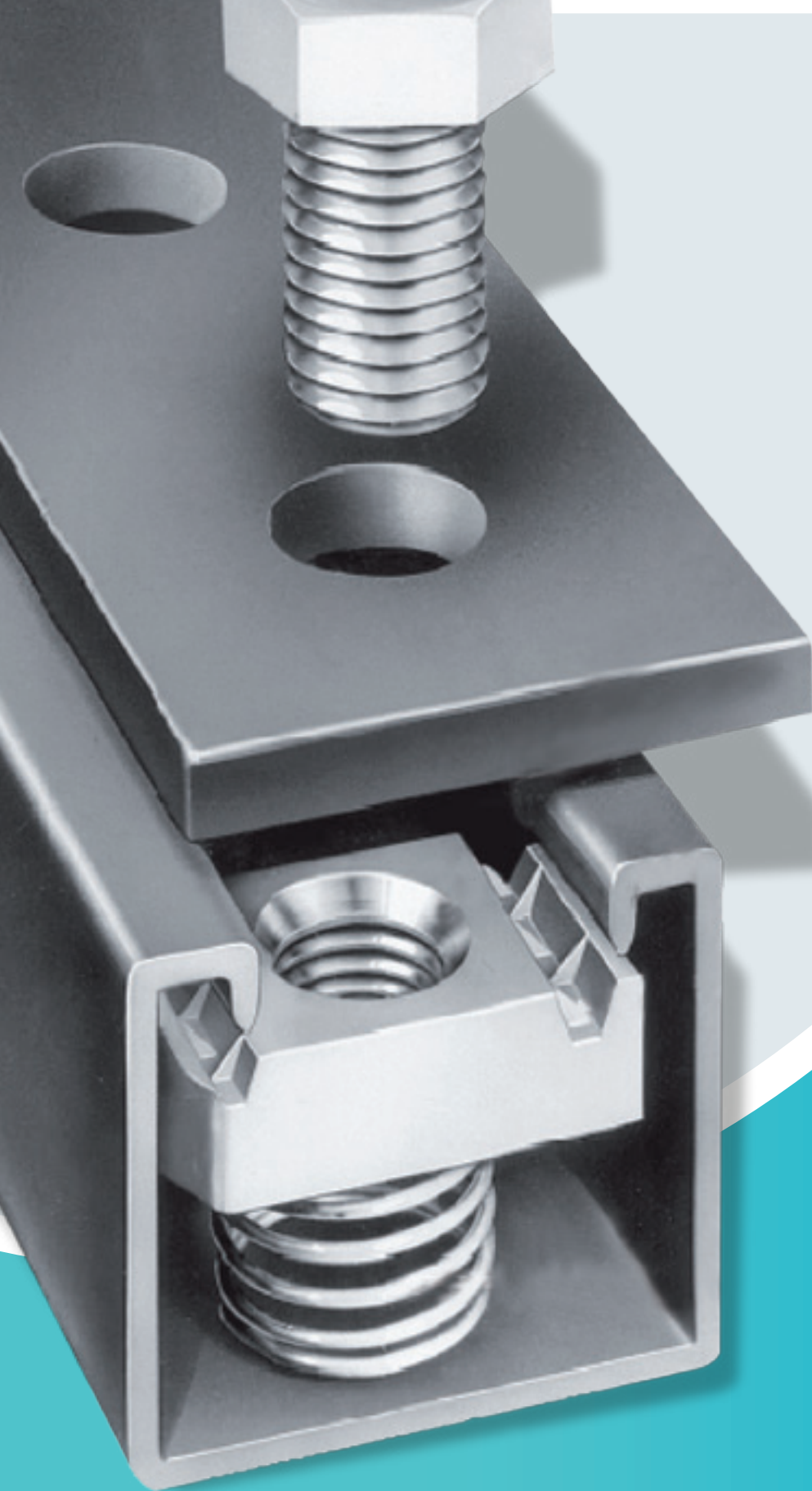

ACCESSORIES

FRAMING SYSTEM ACCESSORIES

Threaded Rods, Hexagon Head Bolts, Hexagon Nuts, Washers

Fully Threaded Rods Grade 4.6 DIN 975

Threaded Rod
(STR)
DIN 975



Zinc Plated Thread	Length (mm)	Load cap. (KN)
M6	2000/3000	2.2
M8	2000/3000	4.0
M10	2000/3000	6.4
M12	2000/3000	12.9
M16	2000/3000	17.3

Order Example : STR - M 12

Round Washers DIN 125

Washers
(SRW)
DIN 125

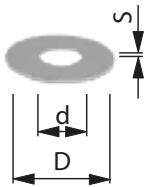

Zinc Plated for bolt	D (mm)	d (mm)	s (mm)
M6	12	6.4	1.6
M8	16	8.4	1.6
M10	21	10.5	2
M12	24	13	2.5
M16	30	17	3

Order Example: SRW - M 12 - DIN 125

Round Washers DIN 440, DIN 9021

Washers (SRW)
DIN 440, DIN 9021

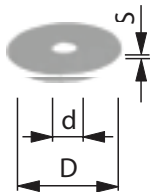

DIN	Zinc Plated for bolt	D (mm)	d (mm)	s (mm)
440	M6	22	6.6	2
9021	M8	24	8.4	2
9021	M10	30	10.5	2.5
440	M12	45	13.5	4
9021	M12	37	13	3
9021	M16	50	17	3

Order Example: SRW - M 12 - DIN 9021

Square Washers SSW

Square Washers
(SSW)

SSW 40/40
for all channels
41/21 Series

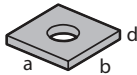

SSW 41/41
for all channels
41/41 Series

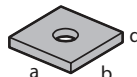

H.D. Glavanized for Bolt	a x b x d (mm)
M10	x 40 x 5 40
M12	x 40 x 5 40
M16	x 40 x 5 40
M6	x 40 x 6 40
M10	x 40 x 6 40
M12	x 40 x 6 40

Order Example: SSW 41/41 - M 12

Hexagon Nuts DIN 934, DIN EN 24032

Hexagon nut (SHN)
DIN 934 or ISO 4032
(= DIN EN 24032)

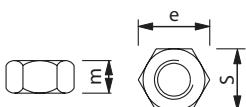

Zinc Plated Thread	S/m DIN (mm)	S/m ISO (mm)	e (mm)
M6	10/5	10/6	11.5
M8	13/6.5	13/7.5	15.0
M10	17/8	16/9.5	19.6
M12	19/10	18/12	21.9
M16	24/13	24/15.5	27.7

Order Example : SHN - M 12

Machine HexHead Bolts DIN 933, DIN 24017

Hex Head Bolt (SHB)
DIN 933 or
EN 24017
(without nut)

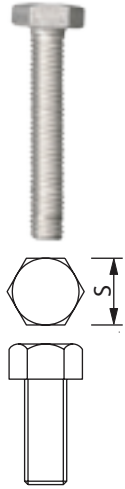

Zinc Plated Dimension	S DIN (mm)	S EN (mm)
M 6 x 12	10	10
M 6 x 25		
M 8 x 25		
M 8 x 40	13	13
M 10 x 20		
M 10 x 30	17	16
M 10 x 45		
M 10 x 60		
M 10 x 70		
M 12 x 22		
M 12 x 25	19	18
M 12 x 30		
M 12 x 40		
M 12 x 50		
M 12 x 60		
M 12 x 80		
M 12 x 90	24	24
M 16 x 40		
M 16 x 60		
M 16 x 90		

Order Example : SHB - M 12

Coupler Sleeves Rounded

Coupler Sleeves (SCS)

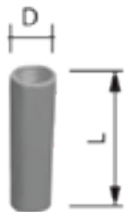

Electroplated Thread	D (mm)	L (mm)	Load .cap (KN)
M6	10/10	15	2.2
M8	12/14	20	4.0
M10	13/16	25	6.4
M12	16/20	30	9.3
M16	21/25	40	17.3
M20	26/32	50	27.0

Order Example: SCS - M 16

Hexagonal Rod Coupler

Hexagonal
Rod Cou-
pler with
view hole
(SHR)



Electroplated Thread	S (mm)	L (mm)	Load cap. (KN)
M10	13	40	6.4
M12	17	40	9.3
M16	22	50	17.3

Order Example: SHR - ZP - M 12

Hexagonal Rod Coupler

Hexagonal
Rod Cou-
pler with
view hole
(SHR)



Size	G		F		H	
	Min.	Max.	Min.	Max.	Min.	Max.
M6	11.05	9.78	10	17.6	18	
M8	14.38	12.73	13	23.5	24	
M10	18.9	16.73	17	29.5	30	
M12	21.1	18.67	19	35.4	36	
M16	26.75	23.67	24	47.0	48	
M20	32.95	29.16	30	58.1	60	
M24	39.55	35.00	36	70.1	72	
M30	50.85	45.00	46	87.8	90	

Specification Requirements:

Dimensions: H, F and G - as above
Threads type: 6H
Mechanical Properties: class 6. Proof Load Strength 600MPa
Finish: Electro-plated

Remarks:

1. Above Coupling Nut to be used with Threaded Rod Class 4.6 or less
2. Threaded Rod to be extended inside the Coupler with distance equal or greater than the nominal Threaded diameter which is equal to H/2

CHANNEL NUTS

Nut without Spring

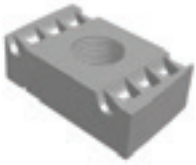

Nut with Short Spring



Nut with Long Spring



Hammer Head Bolt



Material: Zinc plated steel and stainless steel 304 (A2),316 (A4).

Tolerance: Metric thread 6 H acc. DIN 13-20.

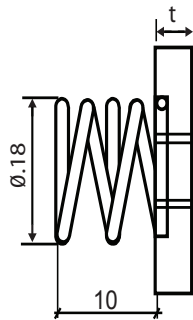
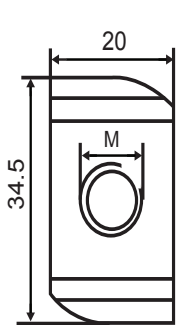

Short Spring

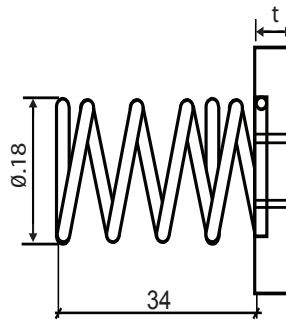

Long Spring

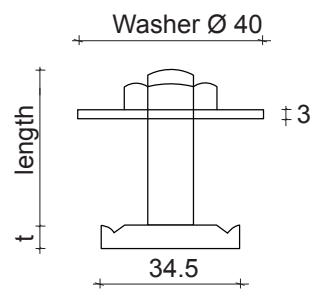

Available length: L 30mm, 40mm, 50mm, 60mm.

Material: Zinc plated.

ALLOWABLE LOAD CAPACITIES FOR CHANNEL NUTS AND BOLTS

Mild Steel Channels, Bolt Material zinc plated or hot dip-galvanized

Thread Size	Pull out (Force Fv (kN)	Longitudinal (Force FL (kN)	Tightening (Torque (Nm)
M6	5.0	1.0	12.0
M8	6.0	2.4	28.0
M10	7.0	3.5	55.0
M12	7.0	5.0	55.0

Stainless Steel Channels, Bolt Material Stainless steel A4

Threaded Size	Pull out (Force Fv (kN)	Longitudinal (Force FL (kN)	Tightening (Torque (Nm)
M6	5.0	0.3	6.5
M8	6.0	0.6	16.0
M10	7.0	1.2	31.5
M12	7.0	1.7	55.0

Note: Do not exceed channel capacity

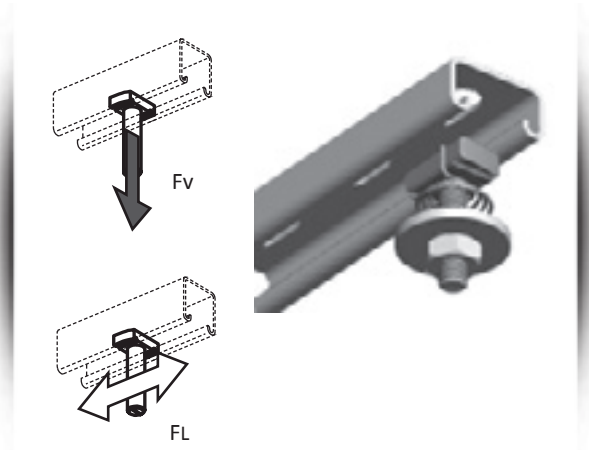

ALLOWABLE LOAD CAPACITIES FOR TOOTHED CHANNEL NUTS AND BOLTS

Mild Steel Toothed Channels, Bolt Material zinc plated or hot dip-galvanized Stainless Steel Toothed Channels, Bolt Material Stainless steel A4

Bolt Size	Longitudinal (Force FL (kN)	Tension Load ((Fv)	Tightening (Torque (Nm)
M6	2.2	5.0	12
M8	4.0	6.0	28
M10	5.0	7.0	55
M12	5.0	7.0	55

Bolt Size	Longitudinal (Force FL (kN)	Tension Load ((Fv)	Tightening (Torque (Nm)
M6	2.2	5.0	6,5
M8	4.0	6.0	16.0
M10	5.0	7.0	31,5
M12	5.0	7.0	55.0

INSTALLATION & FEATURES

No Welding , No Drilling , No Special Tools, Strong, Fast, Economical and Adjustable.



1 Insert the spring nut anywhere along the continuous slotted channel. The rounded nut ends permit easy insertion.

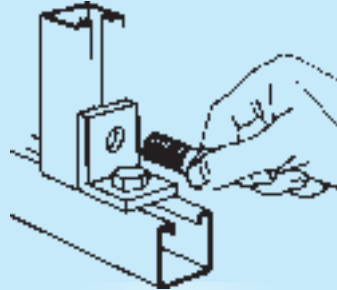

4 Additional channel sections can now be bolted to the fitting already in place by following procedure described in steps 1-3.

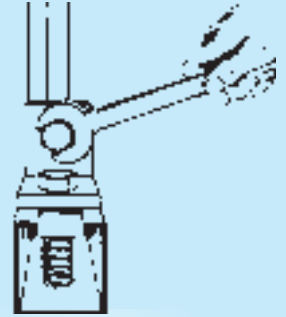

5 Tightening with a wrench locks the serrated teeth of the nut into the intumed edges of the channel, to complete a strong, vise-like connection.

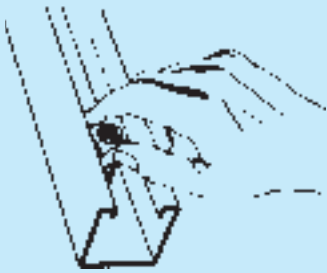

2 A 90° clockwise turn aligns the grooves in the nut with the intumed edges of the channel. The need for drilling holes is eliminated.

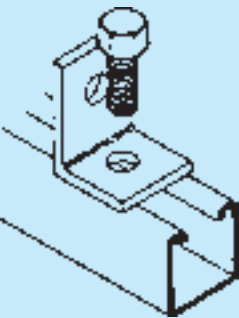

3 Insert the bolt through the fitting and into the spring nut. (See illustration 5 for end view showing the nut in place)

Hex-head bolt connects fitting to channel as it is threaded into spring nut

Chamfer in the nut eases starting of the bolt. Nut teeth make a strong, vise-like grip when tightened against the intumed channel edges

Channel edges and the nut's tapered grooves act as guides to provide fool-proof alignment of connection

Nut teeth grip the channel's intumed edges, tying the channel sides together in a "box" configuration for added strength

Spring allows precision placement anywhere along channel length, then holds the nut in position while the connection is completed

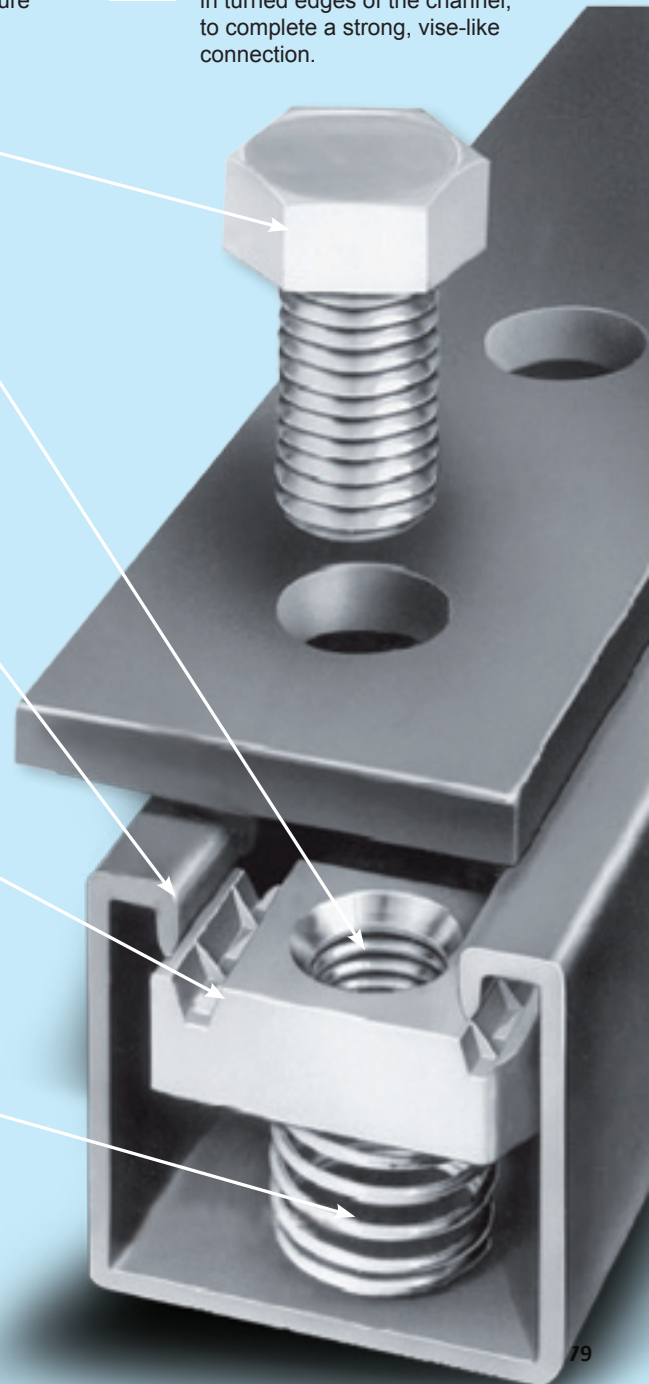

BEAM CLAMP - SBC

SBC

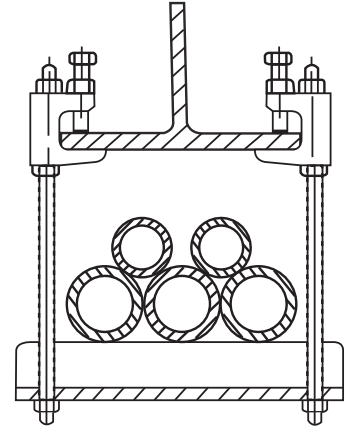

Material: Cast Iron ,hot dip galvanized casting tolerance according to DIN 1684- GTA /17.

- With hexagon head screw DIN 933 8.8, threaded end with cup point according to EN ISO 4753 and locknut DIN 439 .
- For sprinkler systems, heating, ventilation and air conditioning, acoustic tubes and sanitary installation machines and steel constructions.

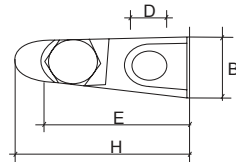
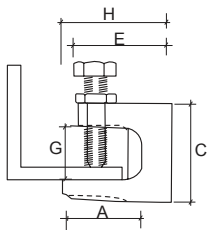

Type	A (mm)	B (mm)	C (mm)	D (mm)	E (mm)	F (mm)	G (mm)	H (mm)	Weight (g)	Safe working load (KN)
SBC8	21.0	19.0	35.0	M8	35.0	M8	18.0	38.0	81.0	1.2
SBC10	29.0	21.0	35.0	M8	41.0	M10	23.0	50.0	147.0	2.5
SBC10	23.0	21.0	42.0	M10	41.0	M10	20.0	44.0	143.0	2.5
SBC12	35.0	23.5	54.0	M12	48.0	M10	26.0	58.0	216.0	3.5
SBC16	30.0	29.5	58.0	M16	55.5	M12	28.0	58.3	318.0	5.5

-Beam Clamps can generally be secured by safety straps.
 -Beam Clamps shall be secured when using Beam for pipes larger than DN65 to avoid slipping of beam.

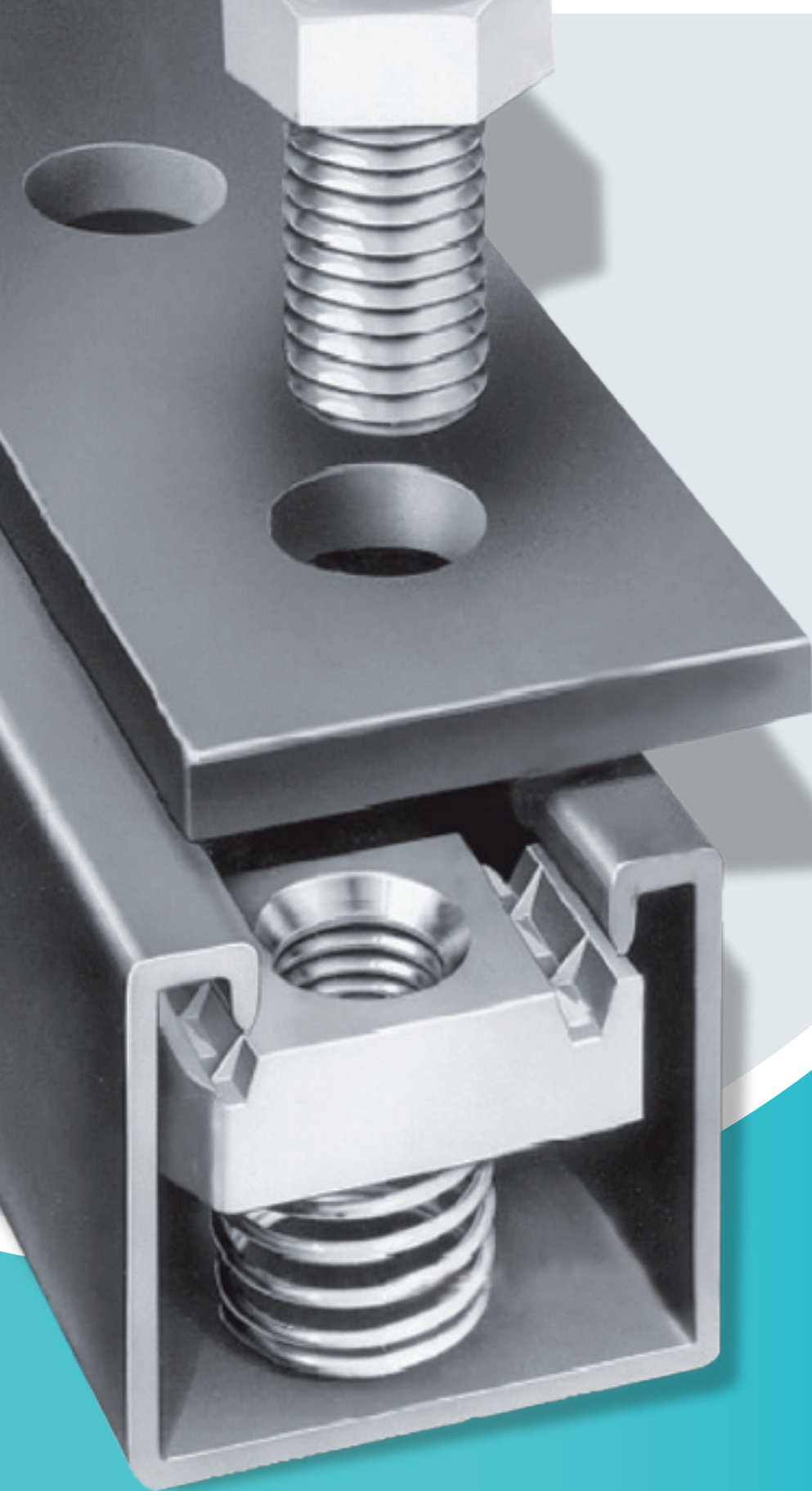

ANCHORS

HEAVY DUTY ANCHORS

General Information

Direction of Loading

The direction of the applied load shall be considered to determine the most appropriate anchor .

The tension and shear components shall be less than the recommended load/design resistance in the direction concerned.

Tensile Loads

Tensile loads are applied along the axis of fixing (see Fig.1).

Common examples include suspended ceiling applications and the suspension of mechanical services, pipework, ductwork, etc.

Shear Loads

Shear loads act at right angles to the axis of fixing and directly against the face of the structural material (see Fig.2).

Shear performance is governed mainly by the shear strength of the bolt material and by the compressive strength of the supporting substrate.

Oblique / Combined Loads

Oblique loads are a combination of tension and shear components (see Fig.3).

If the angle of the applied oblique load is within 10° of pure tension or pure shear, the safe working load for that direction may be assumed. Otherwise, the applied oblique load shall be resolved into its shear and tensile components.

Offset Loads

Offset loads act at right angles to the fixing axis but are offset from the surface (see Fig.4).

In this situation, the deflection of the bolt due to bending needs to be considered as well as the shear capacity of the anchor.

Slotted Holes in Fixture

When fixing anchors through slotted holes; it is important to ensure that there is an adequate surface contact between the washer and the fixture to guarantee a positive clamping force.

If in doubt, a square plate washer with a thickness of 3mm or above would be recommended in place of the standard washer supplied.

Diamond Drilled Holes

When holes are formed in the structure using a diamond drilling system; extra care is required to ensure the holes are thoroughly cleaned by brushing and blowing for at least three times. Also, to make a key for the anchor (particularly if a bonded anchor is installed) the sides of the hole shall be roughened up by inserting a standard masonry bit into the hole attached to a hammer action drilling machine. A resin with minimal shrinkage shall be selected for diamond drilled holes.

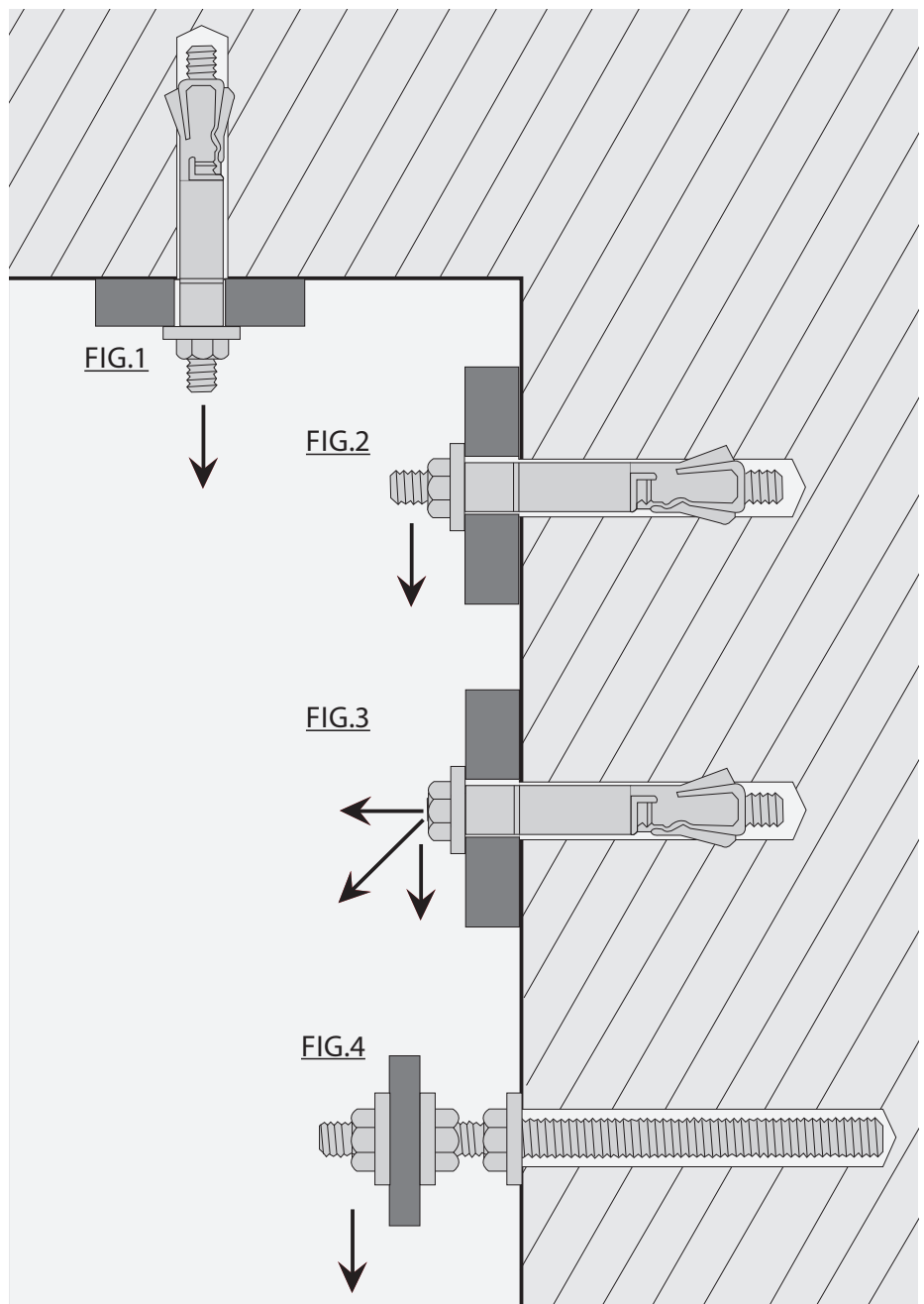

EXPANSION STEEL ANCHOR - STM

Typical Applications:

Cable trays, handrails, brackets, staircases, ladders, machines, window panels, base plates, scaffoldings and frameworks .



STM

Expansion Steel Anchor



STM/H



Features:

- Suitable for all screws or threaded bolts with metric thread.
- Low energy impact, power-saving assembly.
- Multiple removing and fixing.
- Inside threaded anchor, allows great flexibility.
- Can use variable lengths and art of threaded rods or bolts.
- Small edge distance and small distance between anchors.
- Provide uniform load by tightening the screw or hexagon nut, the cone pulls into the expansion anchor and tightens against the drilled hole.
- Suitable for use in concrete and natural stone.

Materials:

- zinc plated steel.
- stainless steel [SS 304 (A2) , SS 316 (A4)].

Technical Data:

Recommended loads (non-cracked concrete C 20/25).

Type (order No)	Tension Load (KN)	Shear Load (KN)	Torque Moment (Nm)	Screw Grade
M6	2.5	2.3	10	4.6
M8	3.3	4.4	17	4.6
M10	4.7	6.5	34	4.6
M12	6.9	8.5	60	4.6

*for cracked Concrete we shall use 0,5 x this value (approximately)

Setting Data:

Edge distance $> 1,5 \times H_{eff}$, distance between anchors $> 3 \times H_{eff}$.
Thickness of foundation $> 2 \times H_{eff}$.

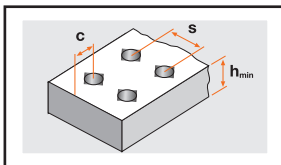

Size	H _{eff} (mm)	Edge Distance C (mm)	Distance Between Anchors S (mm)	Thickness of Foundation h _{min} (mm)	Washer (Ø)	Tightening Torque (Nm)	Spanner size (mm)
M6	40	60	120	100	x 1.6 12	10	10
M8	45	68	135	100	x 1.6 16	20	13
M10	55	83	165	110	x 2.0 20	40	17
M12	70	105	210	140	x 2.5 24	75	19

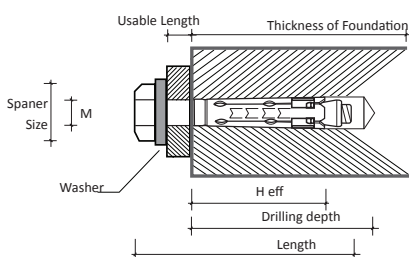

Installation Parameters:

H_{eff} = Effective anchorage depth.

Bolt Size	Length exp. unit (mm)	Drill (Ø) (mm)	Drilling depth (mm)	H _{eff} (mm)	Usable Length (mm)	Screw Ø x Length (mm)
M6	45	10	55	40	5	M6 x 50
M8	50	12	60	45	10	M8 x 60
M10	60	15	80	55	20	M10 x 80
M12	75	18	90	70	25	M12 x 90

DROP IN ANCHOR - SDA

Typical Applications:

- Pipes, ventilation ducts, suspended ceilings, sprinkler systems, brackets, threaded rods, cable trays.

SDA



Materials:

- zinc plated steel.
- stainless steel [SS 304 (A2) , SS 316 (A4)].



Features:

- Provides permanently fixed threaded socket in concrete.
- Use in non-cracked concrete or cracked concrete and natural stone.
- The anchor will spread and tighten against the drilled hole after inserting with setting tool.
- Low setting depth, reduced drilling time.
- Enables cost-effective assembly .
- Multiple removing and fixing.

Technical Data:

Recommended loads (non-cracked concrete C 20/25).

Threaded size	Tension Load (KN)	Shear Load (KN)	Torque Moment (Nm)
M6	2.0	1.2	4.0
M8	3.5	2.2	8.0
M10	4.25	3.5	15.0
M12	5.55	5.0	35.0

*for cracked Concrete we shall use 0,5 x this value (approximately)

Setting Data:

Edge distance > 1.5 x effective anchorage depth, distance between anchors > 3,0 x effective anchorage depth, min. thickness of foundation > 2,5 x H_{eff}.

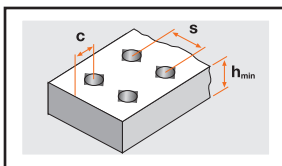

Size	H _{eff} (mm)	Edge Distance C (mm)	Distance Between Anchors S (mm)	Thickness of Foundation h _{min} (mm)	Tightening Torque (Nm)	Spanner size
M6	25	37.5	75	100	4	10
M8	30	45	90	100	9	13
M10	40	60	120	130	17	17
M12	50	75	150	140	30	19

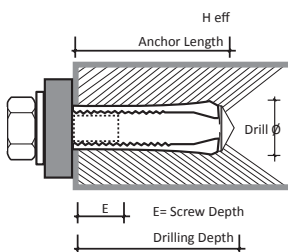

Installation Parameters:

H_{eff} = Effective anchorage depth.

Thread Size	Anchor Length (mm)	Thread Length (mm)	Drill (Ø) (mm)	Drilling Depth (mm)	Effective Anchorage Depth H _{eff} (mm)	Min. Screw Depth E (mm)	Max. Screw Depth E (mm)
M6	25	11	8	25	25	6	12
M8	30	13	10	30	30	8	13
M10	40	15	12	40	40	10	17
M12	50	20	16	50	50	12	18

SLEEVE ANCHOR - SAS

:Typical Applications

Uni-channel ,railings, steel constructions , machines, high-racks, cable support .systems and mechanical fixations

SAS



Materials:

- zinc plated steel.
- stainless steel [SS 304 (A2) , SS 316 (A4)].

Features:

- Suitable for use in concrete, natural stone, brickwork and blockwork- small distance between anchors.
- Optimum performance in most base material types.
- No protruding threads after installation.
- Small distance between anchors and from edge.
- Controlled expansion.
- Zinc plated > 5µm.
- Effective force distribution in the drilled hole.
- Sleeve anchor with hexagon screw or with threaded bolt.

Technical Data:

Recommended loads (non-cracked concrete C 20/25).

Bolt Size	Tension Load (KN)	Shear Load (KN)	Torque Moment (Nm)
M6	1.40	2.0	10
M8	2.45	3.3	25.0
M10	3.5	5.0	40.0
M12

*for cracked Concrete we shall use 0,5 x this value (approximately)

Setting Data:

Edge distance > 1.5 x effective anchorage depth, distance between anchors > 3,0 x effective anchorage depth, min. thickness of foundation > 2,5 x H_{eff}.

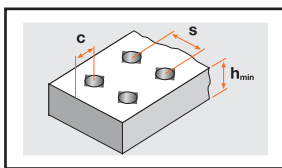

Bolt Size	H _{eff} (mm)	Edge Distance C (mm)	Distance Between Anchors S (mm)	Thickness of Foundation h _{min} (mm)	Washer (∅) (mm)	Tightening Torque (Nm)	Spanner size
M6	35	52.5	105	70	x 1.6 18	8	10
M8	40	60	120	80	x 1.6 16	25	13
M10	50	75	150	100	x 2.0 20	40	17
M12	75	112.5	225	150	x 2.0 26	50	19

Sleeve Anchor - SAS:

with hexagon screw (non-cracked concrete C20/25).

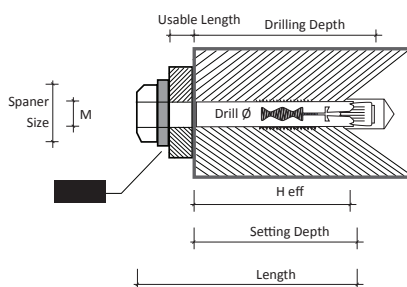

Size	Length (mm)	Drill (∅) (mm)	Hole ∅ in Fixture (mm)	Drilling Depth (mm)	Setting Depth (∅)	H _{eff} (mm)	Min.Usable Length (mm)
M6	45	8	10	55	35	35	5
M6	60	8	10	55	35	35	15
M8	60	10	12	60	40	40	15
M8	80	10	12	60	40	40	25
M10	70	12	14	70	50	50	15
M10	100	12	14	70	60	50	35

.(for cracked Concrete we shall use 0,5 x this value (approximately)*

THROUGH BOLT (WEDGE ANCHOR) - STB

Typical Applications:

Uni - channel, hand rails, steel construction, cable trays, supports, bracket, ducts and shelf feet.

STB



Materials:

- zinc plated steel.
- stainless steel [SS 304 (A2) , SS 316 (A4)].

Features:

- Suitable for use in cracked concrete or in non-cracked concrete and in natural stone.
- Special design of the clip in stainless steel which ensures a safe hold in the hole.
- Torque controlled expansion.
- Zinc plated > 5µm.
- User friendly, face fixing or through fixing.

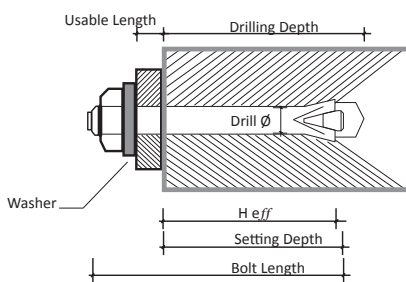
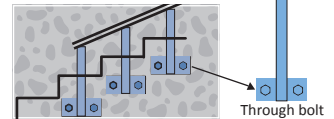
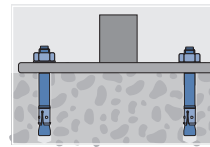
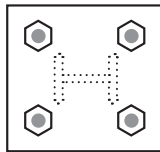

Technical Data:

Through bolt zinc plated (non-cracked concrete C20/25).

Bolt Size	Tension Load (KN)	Shear Load (KN)	Torque Moment (Nm)
M6	2.0	1.90	4.0
M8	4.0	4.0	15.0
M10	5.95	5.95	30.0
M12	7.5	10.0	50.0
M16	12.0	16.0	100

*for cracked Concrete we shall use 0,5 x this value (approximately)

Setting Data:

Edge distance > 1,5 H eff. , distance between anchors > 3 x H eff.
Thickness of foundation > 2 x H eff.

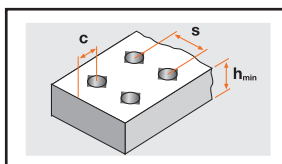

Bolt Size	H eff. (mm)	Edge Distance C (mm)	Distance Between Anchors S (mm)	Washer (Ø)	Thickness of Foundation h_min (mm)	Tightening Torque (Nm)	Spanner Size
M6	40	60	120	x 1.6 12	100	7	10
M8	50	75	150	x 1.6 16	100	14	13
M10	58	87	174	x 2.0 20	120	30	17
M12	68	102	204	x 2.5 24	140	35	19
M16	80	120	240	x 3.0 30	160	80	24

SHIELD ANCHOR - SHA

Features:

- Assembly detachable, multiple removing and fixing.
- Low energy impact, power-saving assembly.
- Force controlled expansion.
- Flexibility inside threaded anchor.
- Variable length and art of threaded rods or bolts.
- By tightening the screw, the cone pulls into the sleeve and tense against the drill hole.
- Small edge distance and small distance between anchor.
- Expansion elements are held together by a spring.
- Optimum taper nut angle for maximum expansion.
- Pressed steel segment ensure consistent dimensional accuracy.
- Provide a projecting stud to support fixture during installation and removal.
- Suitable for use in concrete, natural stone, Brick and sand stone.

Typical Applications:

For fixing : steel construction, handrail, console, bracket, ladders, gate and spacing design.

SHA



Materials:

- zinc plated and die-cast.

Technical Data:

Recommended loads (concrete C 20/25 and in brick work).

Size	Concrete		Torque Concrete N.m
	Tension Load KN	Shear Load KN	
M6	1.2	1.2	10
M8	1.6	1.6	25
M10	3.2	3.2	40
M12	4.8	4.8	60

*for cracked Concrete we shall use 0,5 x this value (approximately)

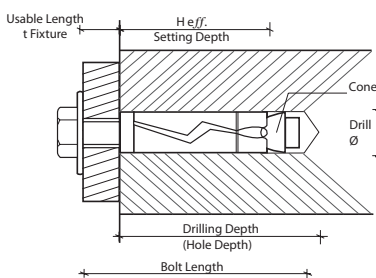

Setting Data:

Edge distance > 1,5 x H *eff.*, distance between anchors > 3 x H *eff.*
Thickness of foundation > 2 x H *eff.*

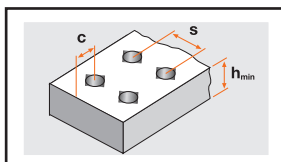

Size	Distance to Edge C (mm)	Distance Between Anchors S (mm)	Min. Thickness of Foundation h _{min} (mm)	H <i>eff.</i> (mm)
M6	52.5	105	70	35
M8	60	120	80	40
M10	75	150	100	50
M12	90	180	120	60

SFSP makes every effort to maintain the accuracy and quality of the information provided in this Catalogue.

However, SFSP cannot guarantee and assumes legal liability or responsibility for the accuracy or completeness of the information provided.

Whilst every care has been exercised in the preparation of this catalogue to ensure that any advice, recommendations or information is accurate, no liability or responsibility of any kind is accepted.

Project working details should be entrusted to appropriately qualified and experienced persons, case by case.

With a policy of continuous product development, SFSP may modify product design and specification without due notice.

In case of any questions or remarks, feel free to contact the R&D Department.